

# CIBSE

JOURNAL



July 2011

The official magazine of the Chartered Institution of Building Services Engineers

## GREEN HOMES

Does the zero carbon definition stack up?

## COOL IDEA

A fresh concept in heat recovery

## CIBSE'S NEW MAN

The thoughts of President Ford

# DESERT BLOOM

QATAR SCORES WITH WORLD CUP INNOVATIONS



## SOUNDS AS GOOD

## AS IT LOOKS



**QUADRILLE ACADEMY**  
FROM CONCORD



With no suspended ceiling to absorb reverberation and hide unsightly cabling and other secondary services, exposed soffits present new challenges for lighting designers. Quadrille Academy is the ideal solution. The special acoustic dampening wings ensure full compliance with Building Bulletin 93 acoustic guidelines, while modular dummy sections keep ceilings clear and clean by housing everything from speakers or lighting controls to fire alarms and sprinkler heads. The result: a sleek, energy-saving solution that sounds as good as it looks.

- **Ideal for use with exposed soffits – no need for additional acoustic panels**
- **Complies in full with Building Bulletin 93 acoustic guidelines**
- **Modular dummy sections for lighting controls, speakers, fire alarms or sprinkler heads**
- **Acoustic dampening wings with cable ways for data / electrical services**
- **Supplied complete with Sylvania 4000k T5 lamps and suspension cables**

Find out more: +44(0) 780 606 2030 / [info.concord@havells-sylvania.com](mailto:info.concord@havells-sylvania.com) / [www.concord-lighting.com](http://www.concord-lighting.com)



# Contents

## NEWS

- 8 News**  
New industry board to push for low carbon construction; MP presses for DECs in Energy Bill; industry gears up for BIM; new feed-in tariffs 'will hit solar renewables'.
- 14 CIBSE News**  
Young engineers' call to promote maths and science in schools; SoPHE chairman awarded Prince Philip Medal; annual general meeting.
- 18 Carrying the torch**  
Peter Raynham explains how the industry needs to address energy efficiency, in his presidential address to the Society of Light and Lighting.
- 19 CIBSE Symposium**  
A new CIBSE event will bring together a range of industry experts to tackle key technical issues facing the sector.

## OPINION

- 22 Your letters**  
How do we ensure that a building will perform in line with its design intentions?
- 24 Regulations**  
Hywel Davies looks at the likely consequences of the government's drive to reduce the burden of regulation of business.
- 25 Manufacturer's viewpoint**  
Former England footballer Gary Neville explains why he has launched a Sustainability In Sport campaign.



34



## QATAR SPECIAL

- 30 Desert bloom**  
Qatar is forging ahead with sustainable development.
- 34 Soccer special**  
Qatar has come up with a 'carbon neutral' design for its 2022 World Cup football stadium, which will be able to stay cool in desert conditions.

## Features

- 26 Interview**  
CIBSE president Andy Ford tells Ewen Rose how respect and collaboration are as important as the technical side of his role.
- 38 Carbon ceiling**  
After the government watered down its 'zero carbon' commitment for new homes, 'low carbon' will be the standard of the future.
- 42 Cool idea**  
A new process shows how it is possible to use natural ventilation in tandem with both heat recovery and cooling.



**'The refurbishment task ahead is on an unprecedented scale – we don't really know how big it is'**  
Page 26

## LEARNING

- 51 CPD**  
Commissioning processes for heating and cooling water distribution in buildings.

## CLASSIFIED

- 56 Products**  
A guide to the latest products and services in the sector.
- 61 Directory**  
Building services suppliers across the industry.

## PEOPLE AND JOBS

- 62 Appointments**  
Find your next job here and online at [jobs.cibsejournal.com](http://jobs.cibsejournal.com)
- 66 Looking ahead**  
A one-day conference on tackling legionella, and the latest training and events in the sector.



Monodraught promises that their roof mounted WINDCATCHER® X-Air natural ventilation system will not leak, and includes a full 10-year installation warranty.

The patented WINDCATCHER X-Air natural ventilation system offers unrivalled levels of weather protection compared to a Classic louvre system.



- **ACTIVLOUVRE®** modulating louvre technology allows the external louvre blade to be adjusted dependent on weather conditions and even closed at roof level to prevent snow being blown through an open louvre arrangement.
- **ACTIVLOUVRE** uses a weather resistant double step louvre profile whilst providing 25% greater levels of ventilation than a conventional Classic louvre profile.
- Profiled internal rain trap louvres are fitted as standard.





www.cibsejournal.com

**Editorial**

**Editor:** Bob Cervi  
 Tel: 01223 273520  
 Email: bcervi@cibsejournal.com  
**Reporter:** Carina Bailey  
 Tel: 01223 273521  
 Email: cbailey@cibsejournal.com  
**Senior designer:** David Houghton  
**Technical editor:** Tim Dwyer

**Advertisement sales**

**Sales manager:** Jim Folley  
 Tel: 020 7324 2786  
 Email: jim.folley@redactive.co.uk  
**Sales consultant:** Mark Palmer  
 Tel: 020 7324 2785  
 Email: mark.palmer@redactive.co.uk  
**Sales executive:** Darren Hale  
 Tel: 020 7880 6206  
 Email: darren.hale@redactive.co.uk  
**Recruitment sales:** Stephen Fontana  
 Tel: 020 7324 2787  
 Email: stephen.fontana@redactive.co.uk  
**Advertising production:** Jane Easterman  
 Tel: 020 7880 6248  
 Email: jane.easterman@redactive.co.uk

**For CIBSE**

**Publishing co-ordinator:** Nicola Hurley  
 Tel: 020 8772 3697, email: nhurley@cibse.org

**Editorial advisory panel**

- George Adams**, engineering director, Spie Matthew Hall
- Laurence Aston**, director, Buro Happold
- Annabel Clasby**, mechanical building services engineer, Atkins
- Patrick Conaghan**, partner, Hoare Lea Consulting Engineers
- Rowan Crowley**, director, inside track
- David Hughes**, building services consultant, MTT Consulting
- Philip King**, director, Hilson Moran
- Chani Leahong**, senior associate, Fulcrum Consulting
- Nick Mead**, group technical director, Imtech Technical Services
- Christopher Pountney**, graduate engineer, AECOM
- Alan Tulla**, independent lighting consultant
- Ged Tyrrell**, managing director, Tyrrell Systems
- Ant Wilson**, director, AECOM
- Morwenna Wilson**, graduate engineer, Arup
- Terry Wyatt**, consultant to Hoare Lea

*CIBSE Journal* is written and produced by Cambridge Publishers Ltd. Tel: 01223 477411. www.cpl.biz 275 Newmarket Road, Cambridge CB5 8JE.

**Editorial copy deadline:** First day of the month preceding the publication month

The opinions expressed in editorial material do not necessarily represent the views of the Chartered Institution of Building Services Engineers (CIBSE). Unless specifically stated, goods or services mentioned in editorial or advertisements are not formally endorsed by CIBSE, which does not guarantee or endorse or accept any liability for any goods and/or services featured in this publication.

CIBSE, 222 Balham High Road, London SW12 9BS  
 Tel: 020 8675 5211. www.cibse.org

©CIBSE Services Ltd. ISSN 1759-846X

**Subscription Enquiries**

If you are not a CIBSE member but would like to receive *CIBSE Journal*, subscribe now! Costs are £80 (UK) and £100 (international). For subscription enquiries, and any change of address information, please contact:  
 Nicola Hurley at nhurley@cibse.org or telephone 020 8772 3697. Individual copies are also available at a cost of £7 per copy plus postage.

Cover photo: Sean Nel/Shutterstock.com



ABC audited circulation: 19,339 January to December 2010



# A greener shelter from the storm

**S**itting in an office in England on a mid-summer's day with wet, stormy weather beating against the windows, one can't help but think about climate change and its impact on our everyday lives. Of course, the unseasonable weather may well have nothing to do with climate change. But it's a good reminder that climate change is out there.

It's a shame, then, that those MEPs sitting in Brussels who are opposed to the EU's plans for tougher emissions targets, don't look out of the window more. At the time of writing, the European parliament was expected to vote for a big rise in Europe's emissions-reduction target for 2020, taking it from 20% to 30%.

Sceptical MEPs from Britain who are opposed to this change are, of course, way out of line with the coalition government's welcome adherence to stringent emissions targets. Ministers' acceptance in May of the independent Committee on Climate Change's proposal for a 50% cut in emissions by 2027 set the UK as an example to the rest of the world. But targets need action plans, and at the end of last month the coalition government took a major step forward in accepting most of the recommendations of the independent Innovation and Growth Team for 'decarbonising' the construction industry (see News, page 8).

Admittedly, many of the measures in the government's new action plan are a rehash of current policies, such as the Green Deal. But the main thrust of the measures is to get leading players across the industry to work together to bring about improvements in procurement, contracts, integrated team-working, enforcement of energy efficiency rules, and so on – all aimed at reducing the impact that the built environment has on climate change. As the new CIBSE president, Andy Ford, tells us this month (Interview, page 26), a more collaborative (and inclusive) team approach to achieving emissions targets is essential.

European policymakers have woken up to the fact that achieving tough emissions targets will depend upon member states being able to make the built environment greener. It's a shame some MEPs don't pay more attention to what's in front of their noses.

Europe has woken up to the fact that achieving emissions targets will depend upon being able to make the built environment greener

**Bob Cervi, Editor**

bcervi@cibsejournal.com







Welcome to a world...

...where renewable technologies are the way we do business.

At Mitsubishi Electric, it is our belief that in the near future, renewable energy-efficient solutions will become the norm for heating, cooling and ventilating commercial spaces. Our renewable technologies already deliver significant energy savings and financial benefits to customers throughout the UK, and we will continue to develop market-leading products that meet or exceed government targets. Welcome to Mitsubishi Electric.

The Renewable Solutions Provider

Making a world  
of difference



Air Conditioning | Commercial Heating  
Domestic Heating | Photovoltaics

[www.mitsubishielectric.co.uk/aircon](http://www.mitsubishielectric.co.uk/aircon)

## In Brief

### INDUSTRY FIGURES HONOURED

Several industry figures were recognised in the Queen's Birthday Honours list. These included the following, all of whom received CBEs: Alan Baxter; Paul Golby, chief executive of E.ON UK; Terence Hill, chairman of Arup Group; Professor Paul William Jowitt, president of the Institution of Civil Engineers; and John McDonough, chief executive of Carillion. Jo da Silva, director of Arup International Development, received an OBE for her humanitarian work.

### 'SUSTAINABLE' PLANNING

The government has published its planning-reform proposals, aimed at giving a 'presumption in favour of sustainable development', and local communities a 'key say' in new developments, according to the Department for Communities and Local Government.

[www.communities.gov.uk](http://www.communities.gov.uk)

### CLIMATE TARGETS MISSED

The government's record on improving energy efficiency in buildings has been too slow, according to a report by the CBI. It's 'climate change tracker' - covering buildings, industry, transport and power sectors - found that ministers had failed on 12 out of 13 climate change 'indicators'. The only policy still on track was for nuclear power.

[www.cbi.org.uk/climatechanger](http://www.cbi.org.uk/climatechanger)

### ENERGY REFORMS CRITICISED

Government plans to reform the electricity market and raise investment capital have been criticised by MPs. Members of the Climate Change Committee do not believe the 'over-complex' proposals will raise the £110bn of capital that the Department of Energy and Climate Change is hoping for.

# Joint board to lead on new low carbon plan

## ● Government to work with industry to implement spate of new reforms

A joint government and industry action plan to 'decarbonise' the construction industry has been published. The plan represents ministers' response to the recent *Final Report* of the independent Innovation and Growth Team (IGT), which called for greater integration of the construction supply chain.

According to new report, *Low Carbon Construction Action Plan*, a Green Construction Board will be set up this month and chaired by construction minister Mark Prisk. Prisk said the plan would provide the 'certainty needed for construction companies to invest in essential new skills, processes and products'.

An updated Carbon Plan and a 'route map' for low carbon infrastructure will be published in October this year, according to the report. The 2050 Group, a cross-industry working party that reported to the IGT, will also be encouraged to continue to meet.

From this autumn the government will begin publishing quarterly reports on a 'rolling two year forward programme of infrastructure and construction projects where public funding has been agreed'. A programme of pilot projects to test innovative projects and processes will also be started soon, the report says. A new industry forum will be set up next summer, with CIBSE among its members, to identify



Paul Morrell: Welcomes new construction plan

**'To ensure that construction to the low carbon challenge, we need to continue this new level of cooperation'**

when the use of building information modelling is appropriate.

The report says compliance with Energy Performance Certificates, will be improved from October when sellers or landlords of both domestic and non-domestic buildings will need to have an EPC before marketing the property. But the report makes no commitment to requiring non-domestic buildings to

use Display Energy Certificates.

Paul Morrell, the Chief Construction Adviser, who chaired the IGT, said: 'To ensure that construction rises to the low carbon challenge, we need to continue this new level of cooperation, so I am also pleased that a joint government and industry board has been set up to ensure implementation of this plan.'

For more information visit:  
[www.bis.gov.uk/constructionigt](http://www.bis.gov.uk/constructionigt)

## MP presses for roll-out of DEC's in bill

An amendment to the Energy Bill could see all commercial buildings having to have display energy certificates (DECs), giving an energy efficiency rating for the property.

Conservative MP Zac Goldsmith has tabled the amendment to the bill, which does not otherwise mention the certificates.

The clause contains a direction for the Secretary of State to require a DEC to be displayed in

all commercial buildings 'in a prominent place' within 12 months of the passing of the bill.

Goldsmith, a keen environmentalist, is a member of the scrutiny committee for the bill.

The MP for Richmond Park and North Kingston told the *Journal*: 'Display Energy Certificates are already mandatory for public sector buildings over 1000 sq m, but not for the commercial sector. This is a simple enabling clause, giving

the government the power to initiate a phased roll-out of DEC's to the commercial sector through secondary legislation. My reason for tabling the amendment is that if you don't know how much energy you are using, you can't manage it. I am pleased that the amendment has the support of the CBI, the UK Green Building Council, the British Property Federation, and the Association for the Conservation of Energy.'



## REGENERATION FOR CAMPUS

The University of Salford is to get a new 16,000 sq m seven storey arts building designed by architects Stride Treglown. Engineering and environmental consultancy Gifford is providing civil and structural engineering, as well as geotechnical services for the building. The new structure will be part of a wider project to regenerate the campus, which will include the refurbishment of existing buildings.



# MoD in drive for energy efficiency

## ● Contractors will be required to monitor energy consumption

The Ministry of Defence is stepping up the monitoring of energy use on its buildings in an attempt to drive down consumption and carbon emissions.

The recently formed Defence Infrastructure Organisation (DIO) will require each of its four new regional prime contractors to open an energy management bureau to monitor energy consumption in each building as part of its Next Generation Estates Contracts programme.

Sub-contractors will also be encouraged to get involved by proposing innovative ideas to prime contractors.

When the prime contracts have been awarded, the contractors will be asked to

survey all sites and buildings in their patch to identify any shortcomings in metering. They will then conduct annual surveys to identify changes that would reduce energy usage.

Contractors will be asked to identify opportunities, and develop business cases, for improvements such as overhauling existing energy distribution networks, fitting

new insulation or heating and ventilation systems – and even disposal plans for energy inefficient buildings.

David Olney, DIO deputy chief executive, said: 'Providing energy-efficient facilities is key in maintaining our

**'Providing energy-efficient facilities is key in maintaining our Armed Forces' operational capability'**

Armed Forces' operational capability. Our future estate contracts provide the perfect opportunity to put energy efficiency at the heart of our estate management and decision-making.'

## CIBSE BUILDING PERFORMANCE AWARDS 2012

Enter now for next year's CIBSE Building Performance Awards, which will recognise excellence in making buildings work.

The awards' 13 categories focus on actual, measured performance, not design intent or performance specifications. The winners will be announced on 8 February 2012 at the awards night at London's Grosvenor House.

For more information, and to enter, visit: [www.cibseawards.org](http://www.cibseawards.org)

### Awards categories

- New Build Project of the Year
- Refurbishment Project Award
- Building Operation Award
- Client Energy Management Award
- Client of the Year
- Building Services Consultancy of the Year
- Contractor of the Year
- Collaborative Working Award
- Energy-using Product Award
- Passive (energy related) Product of the Year
- Commissioning Project of the Year
- Training for Building Performance Award
- Low Carbon Consultant of the Year

## In Brief

### YOUNG ENGINEERS WANTED FOR SOCIETY'S AWARDS

Talented professionals under the age of 35 are being sought by the Society of Public Health Engineers to enter its Young Engineers Award, which is being held in association with WaterAid. Individuals or teams of up to three can enter.

[www.cibse.org/sophe](http://www.cibse.org/sophe)

### ENERGY EMISSIONS REACH HIGH

CO<sub>2</sub> emissions caused by energy usage and production were the highest ever in 2010, according to the International Energy Agency. Global emissions are estimated to have reached 30.6 gigatonnes last year, marking a 5% increase on the previous year.

### UK NUCLEAR PLANTS GET ALL-CLEAR ON CLOSURE

Safety procedures and layouts of nuclear plants will need to be reviewed following the nuclear crisis in Japan, a report from the chief inspector of nuclear installations has found. But inspector Mike Weightman said that there is no need for plants to be closed down.

### UMUNNA SHADOWS CONSTRUCTION

Chuka Umunna MP is Labour's new shadow minister for small business and enterprise, following Gordon Bank's resignation from the post to concentrate on constituency work. Umunna will shadow Mark Prisk, who has responsibility for the construction industry.

### EASIER WAYS TO FIND A JOB ON OUR REFRESHED WEBSITE

Major improvements have been made to our jobs website. These also include a one-click application process to send CVs directly to recruiters and a new CV database for employers, plus email alerts when new jobs are added.

<http://jobs.cibsejournal.com>

# Whitehall and industry push for roll-out of BIM

## ● New implementation plan to develop building information modelling

Building information modelling (BIM) will be required for all public sector construction projects from 2016, the government has announced.

It has formed a 'client BIM mobilisation and implementation group' to drive the adoption of BIM across government.

A BIM implementation plan has also been developed, details of which were due to be released as *CIBSE Journal* went to press.

The BIM initiatives come under the government's construction strategy, which was released in May.

The strategy indicates that the Cabinet Office will co-ordinate an initiative to develop standards 'enabling all members of the supply chain to work collaboratively through building information modelling'.

The strategy document says: 'Government will require fully collaborative 3D BIM (with all project and asset information, documentation and data being electronic) as a minimum by 2016.'

'A staged plan will be published with mandated milestones showing measurable progress at the end of each year.'

Separately, an industry discussion group on BIM has been formed to take forward the idea of a national BIM data library.

Gary Ross, who works for consultancy Capita Symonds, chaired the meeting, which, he reports, was attended by about 20 people including seven of the top BIM consultancies in the UK.



Gary Ross: Welcomes 'meeting of minds'

**'To be able to even organise a meeting of minds such as this, on a topic that is so essential to the future of this industry, was amazing'**

'To be able to even organise a meeting of minds such as this, on a topic that is so essential to the future of this industry, was amazing,' Ross said.

'To get them all to collaborate in an open and honest way is simply incredible, and I only hope that the momentum that we built up on that day will drive us forward to our common goal of making M&E BIM available to all on a common, consistent and managed platform.'

Software vendors will also be invited to participate, in order for the group to understand current developments in the inherent software, and to put pressure on those vendors to work with the group and develop tools that will enable the industry to adopt BIM in a more organised and collaborative way, Ross said.

## New code for Green Deal providers

The government has outlined how it intends to protect consumers taking up the Green Deal,

The Green Deal will enable households to borrow up to £10,000 to pay for the upfront costs of energy efficiency works to their homes, paying it back through the savings made on their energy bills.

A new code, advice line and accreditation service for installers are to be created as part of the Green Deal to ensure customers are protected and have a right of redress when works are carried out.

The plans were set out by



New deal for home owners

the Department for Energy and Climate Change (DECC) in a new document called *Consumer Protection in the Green Deal*.

The accreditation service, UKAS, has been appointed to

ensure assessors and installers adhere to robust standards when participating in the Green Deal.

Meanwhile, a 'progress report' on the planned Green Investment Bank (GIB), which will eventually be used to help finance the Green Deal, has been published by the Department of Business, Innovation and Skills (BIS).

It says that sectors likely to be eligible for financial help initially include offshore wind, non-domestic energy efficiency and waste. [www.bis.gov.uk/greeninvestmentbank](http://www.bis.gov.uk/greeninvestmentbank) [www.decc.gov.uk](http://www.decc.gov.uk)





# Lowara offer the complete package, Pumps and Packaged Pumping Stations for wastewater in Building Services



#### Lowara UK Limited

Millwey Rise Industrial Estate

Axminster, Devon EX13 5HU

Tel: 01297 630230

Fax: 01297 630270

e-mail: [lowaraukenquiries@itt.com](mailto:lowaraukenquiries@itt.com)

<http://www.lowara.co.uk>

#### *We also offer:*

**Booster sets, Rainwater Harvesting systems, Pressurisation sets, UV,  
Variable speed drives, Fire sets, HVAC pumps, Energy Audits, & Borehole pumps.**

w  
w  
w  
.  
l  
o  
w  
a  
r  
a  
.  
c  
o  
.  
u  
k

## In Brief

**NEW SCHOOLS AGENCY TO LEAD ON CONSTRUCTION**

Partnerships for Schools is to be replaced by a new body, the Education Funding Agency, which take over the schools construction programme. The agency will oversee the building of 100 new Private Finance Initiative schools, which will replace some of the Building Schools for the Future projects that the government has cancelled.

[www.education.gov.uk](http://www.education.gov.uk)

**HOUSING STOCK IN ENGLAND STILL GROWING SLOWLY**

The number of houses built in England each year needs to be 234,000 to keep up with demand, says a new study, but fewer than half this number were built in 2010. The study by the Town and Country Planning Association, found that demand is being driven by a growth in single-parent families.

[www.tcpa.org.uk](http://www.tcpa.org.uk)

**DEVELOPER RECORDS BOOST FOR LONDON SCHEMES**

Developer British Land is to spend £1.6bn on new developments across London on six separate sites. Projects will include a 700,000 sq ft +building for UPS and a 500,000 sq ft building for NEQ.

# New feed-in tariffs 'will hit solar renewables'

## ● Larger photovoltaic schemes will no longer come under the tariff system

The solar-energy industry could be severely hit by the announcement of new feed-in tariffs (FiTs), according to a trade association.

The government has confirmed that installations of more than 50kW will not be eligible for FiTs, in a move aimed at protecting funds for small-scale projects.

But the Solar Trade Association says that the move will severely limit cost-effective and accessible public schemes such as those in leisure centres, supermarkets and schools.

The association says innovative schemes using solar power will now become much less likely, with investors moving away to countries where the tariffs are higher.

A spokesman for the Department for Energy and Climate Change (DECC) said that the recent 'fast-track' review of the industry conducted by the department had shown the number of planned larger



Larger solar projects will be hit, says association

**'Crushing solar makes zero economic sense for UK plc because it will lose us major manufacturing opportunities, jobs and global competitiveness'**

## TARIFFS NEW RATES FOR RENEWABLE TECHNOLOGIES

### Solar PV:

- Above 50 kW and up to and including 150 kW total installed capacity (TIC): 19p/kWh
- Above 150kW and up to and including 250 kW TIC: 15p/kWh
- Above 250 kW and up to and including 5 MW, and standalone installations: 8.5p/kWh

### Anaerobic digestion:

- At or below 250kW: 14p/kWh
- Above 250kW and up to and including 500kW: 13p/kWh

Source: DECC. [www.decc.gov.uk](http://www.decc.gov.uk)

solar photovoltaic (PV) projects was much higher than originally expected. Without urgent action, the scheme would have been overwhelmed within a very short period of time,' he said.

'Every 5MW large-scale solar scheme would incur a cost of approximately £1.3m per year, which means that 20 such schemes would incur an annual cost of around £26m – money that could support PV installations for more than 25,000 households.'

But Howard Johns, chairman of the Solar Trade Association, said: 'Ironically, crushing solar makes zero economic sense for UK plc because it will lose us major manufacturing opportunities, jobs and global competitiveness. It also risks locking us in to more expensive energy options in future.'

The government has also announced FiT rates for anaerobic-digestion technologies.

## Movers & Shakers | The latest appointments in the sector



**Jack Pringle**, a partner at Pringle Brandon, is the new deputy chairman of the Construction Industry Council. **Ann Heywood**, and **Ann Skippers** have been appointed as vice chairs of the council.



The Parkside Group has appointed **Aaron Dehara** as architectural adviser, for the central London area. He has worked for more than seven years with door systems companies as an area manager for south-east England.



**Dr Uwe Krueger** has been appointed as the new chief executive of WS Atkins plc. He will succeed Keith Clarke, who has held the position for almost eight years. Dr Krueger will take over as chief executive on 1 August.



The Electrical Contractors Association has appointed **Alun Pearson** as president. Pearson is managing director of A Pearson Electrical Contractors. He has been in the industry for 35 years.



**Jane Boyle** of Buro Happold has been named as BREEM non-domestic 'Assessor of the Year' at BREEM's 21st birthday awards in London. The full list of winners is available at [www.bre.co.uk](http://www.bre.co.uk)



**Bob Eastburn** has been appointed as M&E principal at National Design Consultancy, Warrington. NDC offers the complete M&E, energy and sustainability solution in-house from its national office network.





Specify the best  
in the business



**NICEIC is the name  
specifiers look for  
when they choose  
electricians. That's  
why I'm an NICEIC  
Approved Contractor!**

For guaranteed peace of mind with your project,  
always specify an NICEIC registered contractor.  
It's no coincidence that more than 25,000 of the best  
electrical contractors are NICEIC registered.  
There's no better choice!

To find out more click or call

**0843 290 3417**

[www.niceic.com](http://www.niceic.com)

## Procurement strategy aimed at cutting costs

A government construction procurement strategy is aiming to cut costs by up to 20% by the end of this parliament, in an effort to stimulate growth. Accordingly a new government construction board, chaired by Paul Morrell, chief construction adviser, will be established to co-ordinate and lead construction and infrastructure procurement.

The strategy renews the commitment to publish forward spending plans, to give industry advance notice of workload, and to ensure that government procurement is consistently served by a high level of skills across the whole programme. It commits government to benchmark costs to ensure value for money, and to reduce waste and improve efficiency.

Building information modelling (BIM) will be required across government to deliver project and asset information, data and documents electronically by 2016. A staged plan, with milestones, will be published and updated annually to show measurable progress.

Government sees the introduction of BIM as a means to enable alternative design proposals to be evaluated with comparative ease, and to allow projects to be modelled in three dimensions to eliminate co-ordination errors and subsequent expensive changes, among other benefits.

### Diary date

Summertime heating in buildings and the built environment conference

● 21 July 2011, London  
[www.cibsetraining.co.uk](http://www.cibsetraining.co.uk)

## YEN's cruise to inspire

### ● Young Engineers Network call to help promote maths and science subjects

Seventy CIBSE young engineers gathered aboard a boat on the Thames to find out more about the STEM Ambassador Scheme.

The scheme calls on volunteers to use their skills and experience to act as 'ambassadors' to inspire young people – helping them to see STEM subjects (science, technology, engineering and maths) and careers with a fresh perspective and engage their interest and imagination.

Speaking at the May event, Nicola Kane from YEN London, said: 'YEN is committed to working with

youngsters. The STEM Ambassadors Scheme is an excellent gateway to realise this.'

Also speaking on the night, Vickie Bazalgette, London manager for STEMNET, said: 'STEM Ambassadors can make a difference to young people's future by helping teachers to provide

real-world context for learning. Students are often not aware of how important subjects like maths and science are to their career prospects, and we are always looking for enthusiastic engineers who can help show students how to use their skills.'

Karen Settle, from the YEN London centre, spoke of her own experience of being a STEM Ambassador, and explained that through this role she can inspire

young people. She added: 'Share with them your passion for the industry and the important role that engineers of the future will need to play in making a real difference.'

The event, which was sponsored by Ruskin Air Management and Elta Fans, was a huge success, with 22 potential new Ambassadors signed up to the scheme.

For more information about the scheme, visit [www.stemnet.org.uk](http://www.stemnet.org.uk) For more information about YEN and their events, visit [www.cibse.org/yen](http://www.cibse.org/yen)

● London YEN had a presence at the London and South East Big Bang Fair in June. For more information email [k.settle@cundall.com](mailto:k.settle@cundall.com)

**'Students are often not aware of how important subjects like maths and science are to their career prospects'**

## Have plans, will travel



Anderson Barcellos... winner

Congratulations to Anderson Barcellos, winner of the Ken Dale Travel Bursary 2011.

The bursary is open to CIBSE members in the developmental stage of their career, and makes an award of between £1,500 and £4,000 for the winner to research an aspect of building services outside their home country.

Barcellos plans to travel to China and Japan with his bursary to research 'Building for the

future: How China and Japan are implementing energy efficiency towards their building industry'.

He plans to spend two weeks in each country visiting offices to see what steps are taken in the design process to achieve energy efficiency. His trip is planned for the summer, and he will report back to council later in the year.

For more information about the Ken Dale Travel Bursary, visit [www.cibse.org/awards](http://www.cibse.org/awards)

## Industry needs young talent

More young people need to enter the industry if it is to meet the challenges ahead, said incoming CIBSE president Andy Ford during his presidential address (see interview, p26).

He said industry needs to evolve to combat issues like climate change and energy resource pressure: 'Being a building engineer is a wonderful opportunity to make a difference and to shape a new integrated industry. We need your brains here to create this new industry.'

He also emphasised the need for mutual respect, stating: 'We must respect the wisdom and knowledge accumulated by years in the industry. But we must also respect the new knowledge and research acquired by our graduates. Put the two together and we have a powerful team.'

His full address can be seen at [www.cibse.org](http://www.cibse.org)



# Think, share and do – new president's advice to industry

## ● Chief executive implores members to follow advice of Andy Ford

It is with great pleasure that CIBSE welcomes Andy Ford to the presidency this year. Each president brings something new, and challenges the Institution in different ways, so we're all looking forward to working with him. In his presidential speech he emphasised the need for us all to share knowledge and respect each others strengths and experience.

In this vein of shared learning, we also have a strengthened resolve to reach out and learn from our international members and counterparts. Indeed, for the first time, we have two international vice presidents – Peter Kinsella, from Australia, and Peter Wong in Hong Kong. Together they help to reinforce CIBSE's gathering efforts to widen its international reach – something we know to be important for our development and survival.

The industry is certainly moving to a more global perspective for those companies with reach and capability, plus as information and knowledge is more accessible, traditional differentiators become less important.

These winds of change rightly affect CIBSE – whether we consider it a UK-based organisation with global interests, or an international one, a question

recently discussed by the Board, their view was the latter.

Not surprisingly, we are also seeing more and more of our members working on international projects – and we, as an institution, must keep abreast of this. Not only that, but in the last 10 years our international membership has grown significantly, by 31%. We now have representatives in Bahrain, China, Qatar, Singapore, South Africa, Sri Lanka, Thailand and UAE, and hope that growth continues in the coming years. With this growing international membership base comes a network of international experience and knowledge of different legislation, different working practices and different expertise, all of which make for an incredibly valuable resource to share and tap into.

Speed of travel and communication is certainly making the world a smaller place – but arguably the size, shape and complexity of our challenges are growing apace. While we are increasingly likely to find ourselves working on projects in countries and continents where we have not worked before, that doesn't mean that others don't have experience in these areas, and knowledge of the challenges that might be faced. It would be a wasted opportunity not to do exactly what our new president tells us... to think, share and do.

**Stephen Matthews**

**'We are also seeing more of our members working on international projects – and we, as an institution, must keep abreast of this'**

## SOPHE chairman awarded Prince Philip Medal

Christopher Northey, chairman of the Society of Public Health Engineers (SoPHE) and head of public health at the BDSP Partnership, has been awarded the Prince Philip Medal from City & Guilds. The award was presented to him by the HRH Duke of Edinburgh, the president of City & Guilds, at a ceremony in May in recognition of the outstanding leadership, ability and enthusiasm he has shown throughout his career in the engineering industry.

Northey started his career as a plumbing apprentice for his family business, studying for the City & Guilds Craft and Advanced Craft Certificates in plumbing, and later gained a graduateship diploma in engineering from City & Guilds.



Christopher Northey... 'shocked' to receive his award

Speaking of the award, he said: 'It has been a great surprise and shock to me to win the Prince Philip Medal 2011. City & Guilds has always been an important part of my career development,

from the beginning up to the present day, and I'm honoured to have my work recognised.'

For more information see: [www.cityandguilds.com](http://www.cityandguilds.com)

## LEED training

In the UK, interest in LEED is growing as displaying green credentials becomes a must for many organisations. So CIBSE is working with the US Green Building Council to offer training in preparation for LEED certification. We are interested to hear from anyone who is thinking about training for this standard, specifically at which level you would be looking to gain accreditation – LEED Accredited Professional or LEED Green Associate. Contact Jennie Winterbottom, head of training, at [jwinterbottom@cibse.org](mailto:jwinterbottom@cibse.org)

## Employer of the Year shortlist announced

The shortlist has now been announced for the Employer of the Year Awards, sponsored by Baxi Commercial Division and Heatrae Sadia. Winners will be revealed on 7 July. The shortlist is:

### Small company category

Crofton Design  
JDP

### Medium company category

Alumet Systems (UK) Ltd  
Couch Perry & Wilkes

### Large company category

Arup  
Grontmij

The winning company from each category will receive a trophy and a £1,000 voucher for CIBSE training.

## Closing date for membership applications

The next closing date for applications for the Associate (ACIBSE) and member (MCIBSE) grades is Monday 1 August.

Please make sure your application is complete and you have included:

- An application form;
- Work experience listing;
- Engineering practice report;
- Organisation chart; and
- Development action plan.

For full details of the requirements and application process, visit [www.cibse.org/membership](http://www.cibse.org/membership) or email [membership@cibse.org](mailto:membership@cibse.org)

# Annual general meeting

## ● Board reviews Institution's progress in 2010-11

The Annual general meeting (AGM) of CIBSE was held at The Keyworth Centre, London South Bank University, London SE1, on 5 May 2011. Rob Manning, outgoing president, chaired the meeting. Chief executive Stephen Matthews read the notice convening the meeting.

The minutes of the 33rd AGM of CIBSE, held on Thursday 6 May 2010 and published in the July 2010 issue of the *Journal*, were accepted as a correct record and signed by the chairman.

## Reporting on the Institution's financial affairs

Rob Manning introduced the annual report and financial statements, drawing attention to achievements during the year. These included re-establishing the strategic plan for 2011 to 2016, which is available on the website. A major objective was the recruitment of young people to the industry, which had been supported through the RAEng establishment of visiting professorships in building engineering physics, which was also supported by CIBSE.

International development was a key theme; the Institution now has a vice president in Australia, with another about to take office in Hong Kong. Young Engineers Networks were also being established internationally, supporting membership growth.

Rob Manning went on to refer to the CIBSE Awards, which recognised excellent performance in the industry. The Institution's technical department had been expanded and was now contributing more to societies, groups, the YEN, and to CIBSE's technical guidance. The importance of government consultation responses was also stressed.

A major new development was the knowledge portal, which would improve CIBSE's delivery of technical information around the world, making it available to members on their desktop as part of their membership.

Reference was also made to the importance of energy certification in CIBSE's work.

Rob Manning made reference to his inaugural address, stressing the importance of all roles and disciplines within the industry, and of education. He also referred to Paul Morrell's report, identifying the need to communicate across the professions and wider industry, the value of integrated teams and the need to measure performance.

Rob Manning then introduced Sally Jayne Bonner, audit partner of Chantrey Vellacott DFK LLP, who read the audit report and confirmed that the accounts provided were a true and fair view of the Institution's affairs and had been prepared in accordance with all relevant standards.

Nick Mead, honorary treasurer, presented the financial statements. He pointed out that 2010 had been a challenging year, but that the Institution's finances had performed well in the circumstances.

Income from CIBSE services from certification activities had been affected by the economic climate and the general downturn in the industry, but other areas had performed successfully. Expenditure levels had been closely controlled in view of the financial restrictions and, while overall income was down on the previous year, cost reductions had allowed a small surplus to be generated, and fund balances at the end of the year had increased to just over £3m.

Rob Manning thanked Nick Mead for his work, and staff for the greatly improved financial information now available to the board. He also commended the close control of expenditure that had been achieved.

## Auditors

Nick Mead informed members that Chantrey Vellacott had been CIBSE's auditors for the last three years, and had made a significant contribution to the improvement of systems. He proposed Chantrey Vellacott be appointed as CIBSE's auditors for 2011, and that the board be empowered to agree their

remuneration. This was seconded by Bryan Franklin and approved.

## Special resolution

Nick Mead then presented the special resolution for subscription levels for 2012. There had been much debate over appropriate subscription levels, including discussion with the consultative council of the Institution, and comparisons with the fee levels of equivalent bodies. He stressed the need to maintain and improve the services delivered by the Institution and believed that the proposed rates would deliver this. In particular, he referred to the need to deliver and develop the knowledge portal and the technical content on which it was based.

It was noted that the percentage increase proposed for affiliate members was higher than for the qualified grades, and it was explained that this reflected a greater level of access to services for affiliates, and in particular the knowledge portal. It was also confirmed that the hard copy guide volume previously issued to corporate members was now discontinued, as all documents would be available online.

Nick Mead proposed adoption of the special resolution as set out in the calling notice for the meeting. This was seconded by Andy Ford and approved.

**'A major objective was the recruitment of young people to the industry'**

## Board and Council for 2011/2012

Stephen Matthews declared the following individuals elected to serve as officers, board members and council members following the AGM 2011:

### Officers

<b>President:</b>	Andy Ford
<b>President-elect:</b>	David Fisk
<b>Immediate past president:</b>	Rob Manning
<b>Vice presidents:</b>	George Adams Peter Kinsella Peter Wong
<b>Hon treasurer:</b>	Nick Mead

### Members of the board

<b>Elected members:</b>	Stephen Lisk
-------------------------	--------------

### Members of council

<b>Elected members:</b>	Doug King, James McKenzie-Burrows Mariana Trusson
-------------------------	---





## “The complete solution for car park ventilation.”

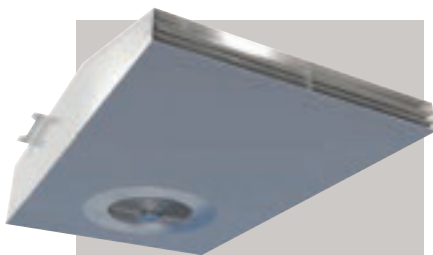

AXUS SVTC CAR PARK  
VENTILATION FANS

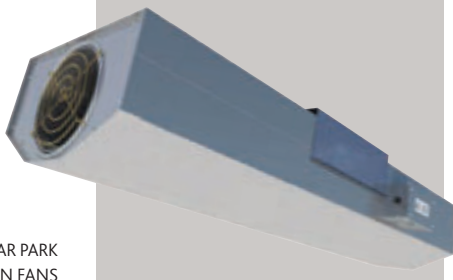

AXUS SVT2 CAR PARK  
VENTILATION FANS

Nuaire, the market leader in ventilation solutions, can help you with all aspects of car park ventilation.

Our car park impulse system is used to control contaminants on a day to day basis, whilst ensuring smoke is removed quickly and efficiently in the event of a fire. With no need for complicated ductwork systems the Nuaire solution optimises space and is cost effective.

#### FROM CONCEPT TO COMPLETION

- DESIGN
- CO-ORDINATION
- MANUFACTURE
- CERTIFIED TO EN 12101-3
- CO CONTROLS
- CFD ANALYSIS

Nuaire. The air of true innovators.



For more information please contact **David Bristol**  
Call **02920 858 595** or email [smoke@nuaire.co.uk](mailto:smoke@nuaire.co.uk)  
Quote reference code **CIBSE0711**.

# Carrying the torch

The lighting industry cannot stand still if it is to resolve key challenges around energy efficiency and user well-being, according to the new president of the SLL. **Jill Entwistle** reports



Peter Raynham gives his inaugural presidential address

**T**he industry still needs to address the 'disconnect' between technical targets and users' experiences, according to the new president of the Society of Light and Lighting (SLL).

In his inaugural address, Peter Raynham said there were undoubtedly shortcomings in the industry that would have a bearing on energy consumption, the quality of the lit environment and human well-being.

'At present lighting is specified so that it meets a number of light technical targets within the lit environment. In general the lighting system is optimised so that it meets those targets with minimum overall energy consumption,' Raynham said.

'The problem is that there is a disconnect between the light technical targets and the impact on people in the space. This is not due to any deliberate policy, but simply because we do not understand the processes involved in human visual performance.'

This was not to imply that the values in the SLL Code for Lighting are wrong, said Raynham, who is editor of the Code and co-author of the SLL Handbook. 'They are tried

and tested values that have been used for many years and they give results that give satisfactory lighting conditions. However, we do not know enough to say they provide the optimum lighting solution.

'Given the drive for energy reduction we cannot sit back and just carry on with the Code values for ever. For this reason there will be significant new advice on the sensible application of lighting targets in the next edition of the Code, due out towards the end of this year.'

Raynham teaches at University College London, chairs the Light and Lighting committee at the British Standards Institution and leads the UK delegation to the European Standards committee for lighting. 'As someone whose job involves a lot of research work I quite like calls for more research,' he said, but added there was a danger that when studies were conducted in artificial environments, erroneous or simplistic conclusions were reached.

'This is not to say that lighting research cannot provide useful insights and help show the way

forward,' he added. 'However, it is not until the new ideas have been tested in real conditions and found to work well in a number of different circumstances that we know we have made progress.'

Raynham also pointed to the need to continue developing the

**Given the drive for energy reduction we cannot sit back and just carry on with the code for ever**

role of the SLL 'in solving the mounting problems faced by lighting in a world where energy use is being restricted'.

'Members of the society collectively are custodians of many thousands of years experience in the field of lighting. This knowledge base is vital to being able to solve the most important problem facing us, which is how to reduce energy consumption while still providing a well-lit environment.'

For more information visit: [www.sll.org.uk](http://www.sll.org.uk)



## Awards Lighting industry figures honoured

Bob Venning, former head of lighting at Arup and the last chairman of the CIBSE Lighting Division before it became the SLL, was given The Lighting Award, a recognition of his outstanding work, contribution to the society and to the lighting industry at large. In a citation written by Barrie Wilde, former head of lighting at BDP Lighting, and read by Eric Maddock, formerly of YRM, Venning was described as epitomising the Arup brand, 'innovation delivered through engineering excellence'.

'He gives of his knowledge and experience generously and freely, and unlike some in lighting

design, he gives it openly without any concern of giving "commercial gain",', wrote Wilde in his tribute.

The President's Medal was awarded to Ernest Wotton, a founder member of the International Association of Lighting Designers (IALD) and former lighting consultant in Toronto, Canada, where he moved in 1956 to head up a street lighting company. This year's Leon Gaster award went to Christophe Reinhart and Valerio LoVerso for their paper, *A rules of thumb-based design sequence for diffuse daylight*. The Walsh Weston award was given to D Miller, A Bierman, MG Figueiro,

ES Schernhammer and MS Rea for 'Ecological measurements of light exposure, activity and circadian disruption'.

Fellowships were awarded to immediate past president Alan Tulla and SLL secretary Liz Peck. The Regional Award went to Andrew Saville for his contribution to the Home Counties North East branch of the SLL.

Sponsors in Partnership certificates were given to representatives of Erco, Holophane Europe, Philips Lighting, Thorn Lighting and Tridonic. The evening was chaired by Kevin Theobald, president-elect of the IALD.



## Peer to peer

A new CIBSE event this year will bring together a wide range of industry experts and practitioners to tackle key technical questions facing the sector

This autumn will see the first of a new-style CIBSE two-day technical event that aims to cover a diverse range of topics that will be of interest to the wider built environment sector. The Technical Symposium, sponsored by Lochinvar, takes place at De Montfort University in Leicester from 6-7 September. It will include presentations from a mix of academics, researchers, industry experts, consultants and developers.

The presentations will be formally reviewed and published, and will provide opportunities for both industry and the academic and research community to interact to

create ideas for future application and development.

Hywel Davies, CIBSE technical director, said: 'I welcome the renewed opportunity for academics, researchers and, importantly, industry to join together to present peer-reviewed papers on areas of current research and development. This event provides a wonderful opportunity where our young engineers can also meet and share in the experience of more seasoned practitioners.'

Topics to be covered include: project management in engineering the built environment; building engineering systems integration and design; renewable and

sustainable technologies; and engineering the refurbishment and renewal of existing services. Scheduled speakers include:

- Keith Murray from the University of the Highlands and Islands, who will consider the challenges that have to be addressed beyond energy and CO<sub>2</sub> to sustain the built environment;
- Mehreen Gul of Heriot Watt University, who will look at the implications of predicted climate change for overheating of naturally ventilated office buildings;
- Stephen Porritt of De Montfort University, who will assess interventions that can be made to reduce dwelling overheating during heat waves without the use of 'cheap' air conditioning;
- Gavin Summerson of BRE, who will provide an overview of lessons learnt from piloting BREEAM for domestic refurbishment; and
- Ken Dooley of Granlund, who will show how to motivate occupants to use less energy using smart systems.

Professor Tim Dwyer, who helped to create the event, said: 'De Montfort University's generous support for the event has allowed CIBSE to keep the costs as low as practicable. As time is seen as being at a premium for all potential attendees, the sessions

This event provides an opportunity for young engineers to meet and share in the experience of more seasoned practitioners

will commence at mid-morning on the first day to allow many to travel on that same day, saving an extra overnight stay.

'For those that want to travel the day before, and for the intervening night, the university is making basic but good-quality overnight accommodation available from £24.'

For more details and to book a place visit [www.cibse.org/events](http://www.cibse.org/events)



**BlueSense**  
Intelligent Control

Save energy and costs  
with **BlueSense Controls**

BlueSense philosophy combines intelligent control technologies with energy saving products, services and engineering expertise. BlueSense helps meet energy reduction commitments by optimising the equipment performance, improving energy efficiency, saving money and increasing equipment life expectancy.

BlueSense Includes an Extended Warranty

- ▶ 3 years with BlueSense packages.
  - ▶ 5 years with BlueSense package and Post Installation Commissioning.
- Please quote BlueSense with your order or contact our specialist sales team for further information. Call +44 (0)8448 15 60 60.



Reduce Energy Consumption



Lower Environmental Impact



Improve Air Quality



Extend Equipment Life



Tel: +44(0)8448 15 60 60  
[www.ves.co.uk/products/VESControls](http://www.ves.co.uk/products/VESControls)

# CIBSE BUILDING PERFORMANCE AWARDS 2012

Wednesday 8 February  
Grosvenor House, London

## Open for entries

### RECOGNISING EXCELLENCE IN MAKING BUILDINGS WORK

#### Who should enter?

The awards are open to any organisation responsible for the design, commissioning, construction, installation and operation of sustainable buildings and the manufacturers whose technologies enable energy efficiency.

#### The categories

- » New Build Project of the Year
- » Refurbishment Project Award
- » Building Operation Award
- » Client Energy Management Award
- » Client of the Year
- » Building Services Consultancy of the Year
- » Contractor of the Year
- » Collaborative Working Award
- » Energy-using Product Award
- » Passive (energy related) Product of the Year
- » Commissioning Project of the Year
- » Training for Building Performance Award
- » Low Carbon Consultant of the Year

#### Why enter?

- » Be recognised as the best in your field
- » Gain competitive advantage
- » Enhance your business's corporate & social reputation
- » Raise your profile
- » Reward your team and boost morale
- » Entering is **FREE OF CHARGE**

[www.cibseawards.org](http://www.cibseawards.org)







The CIBSE Building Performance Awards recognise, reward and celebrate the best performance, innovation and practice in building and building services.

Enter now at:

[www.cibseawards.org](http://www.cibseawards.org)

For entry or table booking enquiries please contact  
juliette.bond@redactive.co.uk or 020 7324 2771

For sponsorship enquiries please contact  
jim.folley@redactive.co.uk  
or 020 7324 2786

# Your letters

**This month:** How do we ensure a building will perform in line with its design intentions?

**Penalise owners whose buildings don't perform**

I would like to suggest some input from CIBSE to the planned changes to Part L of the Building Regulations: the carbon emissions declared on the Energy Performance Certificate should be verified by measurement of actual energy consumption at a suitable interval after completion and handover to the users. If the measured emissions do not coincide with the declared figures based on the design, then the building should be classed as non-compliant with the regulations, and appropriate penalties should be applied to the owner.

This may go some way to tackling the situation where various 'green' technologies are installed to get the building through the regulations, but then not used. There is a rumour that many biomass boilers are installed and not used, as the site then runs on the gas-fired back-up boiler. Other low carbon technologies present challenges to contractors unfamiliar with them – and proving their correct operation, or even achieving final commissioning,



How to ensure that a building will perform in line with its design intentions after it has been handed over to the client?

can be tortuous and time-consuming. A commercial client has little incentive to take on the trouble and expense of operating a low carbon system, and fuel costs are a tiny fraction of his overheads.

Of course, if we could design buildings to need less energy in the first place this would not be a problem, but the current situation demands a mixture of approaches to reducing carbon emissions – and, as engineers, we have the role of installing technical solutions which may be misused or not used at all.

*Peter Hill*

Simply calling something 'green' or 'renewable' seems to be enough – no rigorous analysis is required

**Less of the thumbscrews and a little bit more analysis please**

You report that Paul King, chief executive of the UK Green Building Council, wants home owners to be banned from selling their property if they fail to meet energy efficiency targets (the *Journal*, April 2011). That's the stuff. The next step should be to bring back the rack and thumbscrew for those who question such proposals.

The difficulty I have with many of the proposals put forward by various interest groups is that they rarely seem to provide hard facts and figures. The mere fact that something can be called 'green' or 'renewable' seems to be enough – no rigorous analysis is required or welcomed.

Which is why I was glad to see the unbiased report in the *Journal* on tests carried out on small wind turbines in urban locations (the *Journal*, June 2011). This is the kind of useful knowledge we need if a proper engineering approach is to be made towards solving the problems in a practical fashion, avoiding a lot of expensive and self-defeating actions.

*Gerard Palmer FCIBSE*

**Never mind the log book, why not a FSH?**

It is the same every time. Everyone is in a good mood, the building is at its best, the building handover is complete, you take a satisfying slurp of tea ... and then



Comprehensive range



Low energy humidifiers

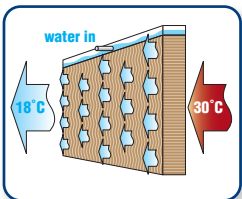

Up to 12°C evaporative cooling



Free lunchtime CPD seminars

## JS Humidifiers

- ✓ Expert assistance in design and selection
- ✓ Humidifier run cost analysis
- ✓ Carbon footprint analysis

Free A3 psychrometric charts



E: sales@jshumidifiers.com  
 T: +44 (0)1903 850200  
 W: www.jshumidifiers.com

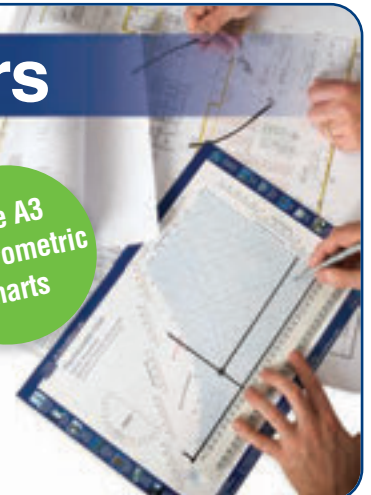



**X CIBSE.COM  
READERS' POLL**

Each month we will be posing a question to readers on our website, [www.cibsejournal.com](http://www.cibsejournal.com)

**Last month we asked:**  
*Will the government's proposed Green Deal deliver what's needed to bring in a green economy one day?*

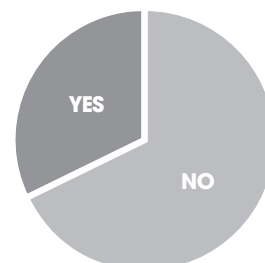

Respondents were split 2:1 against the Green Deal: 68% thought it would not succeed, with 32% believing it would.

**This month the question is:**  
*Do employers in the sector generally do a reasonable job in the mentoring, training and development of their young engineers?*

Visit [www.cibsejournal.com](http://www.cibsejournal.com) to have your say.

you give them the logbook. The client's face drops, the harsh lettering and contrasting colours causing a pain that only ceases when it has been hurriedly hidden on the top shelf, maybe never to be looked at again.

After years of careful presentation and detailed design, the single most important document in the building – the instructions on how to use your carefully crafted masterpiece, the legacy of your involvement with the project – is a badly put-together Word document.

The standard CIBSE logbook has to be the single ugliest and most incomprehensible piece of documentation that has ever existed.

The current version is cramped and has as much style as your stereotyped engineer. Make it more attractive so that it fulfils its purpose and develops with the building and is an object of pride for the designer.

Car log books manage it. Maybe we could get to the stage when we're selling buildings with a 'full service history'?  
*Will South*

**Rush towards efficiency ignores comfort**

I appreciated Tim Dwyer's CPD on indoor air quality (IAQ) (the *Journal*, April 2011). It concerns me that the drive towards energy efficiency, particularly with regard to retrofit projects, may not be

giving due consideration to – and as a result may be compromised by – comfort demands.

Conversely, I think that the same demands are not being used as effectively as they could be to drive change and justify energy performance measures.

This is an area that might be worthwhile developing as a CIBSE Special Interest Group – perhaps not focusing on IAQ but looking more broadly at indoor environmental quality, comfort and well-being.

There would be a benefit in a specific group to consolidate existing knowledge and resources, and track current understanding.

*Michael Birnie*

**The New ReCooler**  
*now available from Fläkt Woods*

The New ReCooler System from Fläkt Woods offers integrated cooling within the Air Handling Unit whilst delivering the lowest power consumption available on the market utilising thermal wheel.

It incorporates Plug & Play design technology – no on site installation of Condensing Units, Pipework or Controls. ReCooler Package is manufactured, commissioned and tested at the factory, simply provide power and start cooling.



**ReCooler**  
Saves time, space,  
capital and energy costs



**ReCooler**  
*eQ Air Handling Unit with integrated cooling*

# IN AND OUT



The government is determined to reduce the burden of regulation on business but, asks **Hywel Davies**, what are the consequences of this?

New regulations are subject to rigorous checks on costs and benefits. If they are not cost-beneficial they must meet the 'one in, one out' (OIOO) rule, whereby the cost burden of a new regulation must be offset by scrapping a regulation with at least as great a cost burden. For thorough scrutiny, two committees and a team of civil servants oversee this.

This means policy proposals have to be costed, but it is not always clear whether a new proposal has been through this check when it is announced. For example, has the policy of not allowing a landlord to let a building with an F rating been through this test? If not, will it pass? While the process introduces clarity over burdens, it may lead to uncertainty.

The government has set up ways to review all existing regulations; the Cabinet Office is running a rolling review of legislation by theme, with formal independent reviews of various areas of legislation.

Health and safety (H&S) legislation is being reviewed by a panel chaired by Prof. Ragnar Löfstedt, a risk management specialist. He will consider opportunities to reduce

the burden of health and safety legislation on UK businesses while maintaining progress in improving outcomes. He will make recommendations to ministers by the end of October. Löfstedt has called for interested parties to submit evidence about the scope to reduce the burden of H&S regulation in the UK. This is an opportunity for CIBSE members to contribute to the institution's response. H&S regulations affect many aspects of building services engineering, so here is a chance to contribute to the process.

The first five questions ask about H&S regulations and Approved Codes of Practice (ACoPs). For example, are there any regulations or ACoPs that:

- Have improved health and safety and should not be changed?
- Need to be simplified?
- It would be helpful to merge together?
- Could be abolished without any negative effect on the health and safety of individuals?

**This may be your best chance to influence the regulatory burdens on your business for some time**

- Create significant additional business burdens but have limited impact on health or safety?

Further questions ask:

- To what extent does the 'reasonably practicable' concept help manage the regulatory burden?
- Are there examples where health and safety regulations have led to unreasonable outcomes?
- Are there lessons to be learned from the way other EU countries approach H&S regulation, either in their overall approach or the way they regulate risks or hazards?
- Can you provide evidence that the requirements of EU directives have or have not been unnecessarily enhanced ('gold-plated') when incorporated into UK regulations?
- Does health and safety law place responsibility in an appropriate way on those that create risk? If not, what changes would be required?

The deadline to submit comments to the Department for Work and Pensions is 29 July 2011.

Members with comments are asked to submit them to the CIBSE Technical Department by email to [technical@cibse.org](mailto:technical@cibse.org) by Friday 15 July.

The link to the consultation details on the DWP website is [www.dwp.gov.uk/docs/lofstedt-call-for-evidence.pdf](http://www.dwp.gov.uk/docs/lofstedt-call-for-evidence.pdf)

● **HYWEL DAVIES** is technical director of CIBSE

## The perfect combination..... P-Sensor and the CMR Velogrid



P-Sensor

CMR are the inventors and manufacturers of both the P-Sensor and the Velogrid. The Velogrids are made to measure to fit any ductsize up to 3m x 3m and the P-Sensor has a keyboard to easily enter : duct height - width - density - magnification factor and the scaling in m/s - m3/s - m3/h - l/s. It can even work out the Air Change rate. And the BMS gets three linear volume signal outputs of 0..10V 4..20mA and an addressable Modbus rtu bus.

VELOGRID

Velocity Averaging Sensor

CMR CONTROLS Ltd

22 Repton Court Repton Close  
Basildon Essex SS13 1LN GB  
[www.cmr-controls.com](http://www.cmr-controls.com)

Tel +44 (0) 1268 287222  
Fax +44 (0) 1268 287099  
[sales@cmr-controls.com](mailto:sales@cmr-controls.com)





## MANUFACTURER'S VIEWPOINT

Former England and Manchester United footballer **Gary Neville** explains why he has launched a Sustainability In Sport campaign, backed by Mitsubishi Electric, sponsor of this column



Having been a partner in King Associates, a Manchester-based mechanical electrical consultancy for the past six years, I have been aware of how sustainability has grown as an issue for everyone involved in the built environment. As I approached the end of my football career, I also questioned my own lifestyle and I wanted to find a way to change the way I live and the impact that my family and I have on the environment.

This is why I am about to build my own zero carbon home, having just received planning permission under PPS7 (Planning Policy Statement 7). I also wanted to see if we could find ways of encouraging people to look at sustainability without

appearing to badger them, and I am aware that, to be effective in today's world, sustainability has to be commercially viable.

When a partner in the consultancy came up with a three-word concept, 'sustainability in sport', I thought this could work. I was just a concept until recently but, when I started thinking about retiring from football, I thought: 'I want to make a statement and try to make it aspirational.'

Sustainability in Sport has therefore been created with the primary objective of supporting the continuing growth of sport within UK communities, while reducing the associated environmental impacts.

Over the next five years we hope to introduce a sustainability charter for professional football clubs and sports organisations

I decided six months ago that I wanted to launch Sustainability in Sport as part of my testimonial match and we partnered with Mitsubishi Electric because of the great work they have already done in this area. Over the next five years we hope to increase awareness of the benefits of adopting a more sustainable approach and introduce a sustainability charter for sports organisations. We are also hoping to create national awards and raise awareness of the need to focus on sustainability at all levels in our community.

I'd like sustainability to become a trendier topic, as I am aware of the cynicism out in the wider community towards the 'green' agenda. But I am also aware of the power and breadth of influence that football has – which we can all see when we look at the impact that programmes like Kick It Out have had on racism.

I hope Sustainability in Sport can have a similar impact, and that I am now in a position to help drive the sustainability agenda into all aspects and all levels of sport in the UK.

Sustainability in Sport was launched at Gary Neville's Testimonial match on 24 May. [www.sustainabilityinsport.com](http://www.sustainabilityinsport.com)



## Life Safety Systems

Fire safety is a key aspect in the management of all buildings. Correctly designed, specified and tested **fire safety solutions** can help ensure human safety, whilst helping to minimise potential financial losses incurred through the outbreak of fire.

Fläkt Woods is a pioneer in the fire safety field, having built up vast applicational knowledge through involvement in many major construction projects. The ability to offer a **full package of equipment**, coupled with our vast experience, makes Fläkt Woods the ideal provider of fire safety solutions.

Our wide product range includes **fans, dampers and controls**, all designed to encompass the stringent requirements of fire safety, and to surpass, when tested, the most recent fire safety regulations.

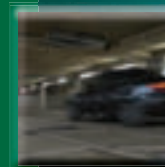

## Ventilation Solutions by Fläkt Woods Limited

New CIBSE president Andy Ford says building services engineers need to become a lot better at explaining what they do

# WORKING



## Respect and collaboration will be as much a part of his CIBSE presidency as technical matters, Andy Ford tells **Ewen Rose**

**T**he new CIBSE president believes in collaboration. Building services engineers often see themselves leading the process for decarbonising buildings, but Andy Ford believes the industry has to change. 'We can lead the integration but we can't lead the whole process,' he says.

'We know how buildings physically interact with human senses and we have methodologies to quantify and predict this; that knowledge is our greatest business asset and our most saleable commodity, but the scale of the task facing us is unprecedented and the burden has to be shared.'

The word 'respect' comes up a lot in conversation with Ford, who is technical director at engineering group Mott MacDonald. He is a firm believer in respecting people, getting beyond prejudice to understand what they can contribute. Respecting each other's expertise,

to achieve our ambitions,' says Ford. 'Share what we know and how it can be applied, and our status as engineers will rise.'

Respect for others creates a desire to share knowledge with 'adjacent' professions, who are equally focused on the challenge to decarbonise buildings.

'Our profession was the only one thinking about building behaviour and performance for years – so we have an advantage over everyone else who is now concerned with this area,' he says. 'Now our task is to get better at explaining our understanding and at evolving our solutions.'

### Comfort zone

The problem is that, for most of those years, the industry was thinking about making sure buildings satisfied peak demands; a different mind-set will be needed to reduce that demand, he says. 'For the Greater Comfort of Mankind keeps coming into my

**6** We know really useful things, and that knowledge is our greatest business asset and our most saleable commodity

# TOGETHER

knowledge and ambitions will be key to delivering the low carbon agenda, he says.

'Throughout my career I have heard people in the construction and property industry make snide remarks about architects, engineers, contractors, and consultants – all of which are simply based upon prejudice. These are self-perpetuating, and become embedded very early in the teaching and training process. They compromise effective team-building and problem-solving. They must end.'

He wants a more inclusive CIBSE, with people from wider backgrounds and skills encouraged to aim for chartered engineer status. 'Respect brings diversity, and we need a much more diverse industry if we are

mind. We have raised people's expectations for comfort; now we have to keep delivering a comfortable world, but only using 10% or 20% of the energy.'

He believes that building services engineers are being challenged to move out of their 'comfort zone' and must ditch some of their favourite rules of thumb – and that our understanding of building physics and psychology is as important as building services.

'The old rules no longer apply. We have to stop being obsessed with brand new non-domestic buildings and focus on *all* buildings. The refurbishment task ahead is on an unprecedented scale – we don't really know how big it is – and the overhaul of

The size of the low carbon refurbishment programme gives us an opportunity to create a continuity of work that will allow practices to recruit and retain talented people

The industry needs to be more inclusive if it is going to be able to recruit people from a wider base, insists Andy Ford



the domestic sector will not be successful without our input.'

CIBSE has a key role to play in sharing its knowledge and experience with other professions and institutions. The development of the institution's online Knowledge Portal will play a pivotal role, says Ford.

'I believe that when you become a member of CIBSE you own all of that knowledge – your peers created it and it is yours. You have paid to join and should not be expected to pay again when you want to gain access to your institution's bank of knowledge. Online tools now make that possible.'

There is also a data explosion coming that will challenge traditional working practices; this is another area that CIBSE can lead on. 'With the deployment of smart meters, we will suddenly have access to more energy performance information than ever before. We must be able to analyse and make best use of that data. If this was combined with a full roll-out of Display Energy Certificates and proper benchmarking, we could at last start a cycle of continuous improvement.'

Ford's principle of respect has informed his career and the values behind Fulcrum, the practice he founded and eventually sold to Mott MacDonald in 2009. Like many building services engineers, he came into the sector by accident, having studied for a mechanical engineering degree at the University of Bath after a period of working in diesel engine manufacturing.

'I liked making things and was attracted by the idea of making really big things – buildings. I also find the whole process fascinating.'

It was architects, with whom he shared flats during his degree, who introduced him to buildings and, after graduating

in 1974 aged 21, he applied for a job with Max Fordham & Partners. Attracted by the 'democratic' structure of the company, he took to the hands-on learning and adherence to 'first principles' that characterised the Fordham approach.

### Inclusiveness

When he founded Fulcrum, Ford wanted to create a 'socially normal' business model: 'It seemed to me that a lot of people coming up through the tools were being ignored. They had a lot to offer, but weren't treated with equal respect. Everyone needs to feel they are part of the solution – feel empowered. I also think it is important for people to have a broad view and be interested in other things: they need to be able to see the full picture when designing a building and not simply focus on building services.'

The industry needs to be more inclusive so that it can recruit and retain from a broad base, Ford believes. 'We must break free from the relentless cycle that has defined our sector for years. Work comes and goes and we hire and fire. We lose good people because we continually move from boom to bust.'

'The size of the low carbon refurbishment programme and the requirement to control the lifecycle gives us an opportunity to create an industry with the continuity of work that will allow practices to recruit and retain talented people. Much of the sustainability expertise lies with our youngest engineers. It has only been taught for the last 10 years, after all, so experienced engineers have to turn to young colleagues for guidance. That creates a certain tension, but I believe it is very positive and highlights the importance of a diverse workforce.'

The supply chain is evolving quickly, and Ford believes that building services

# Renewables Roadshow

powered by PLUMB CENTER

Is your business looking to get on board the renewables revolution? Then get on board the Renewables Roadshow this September.

Register for your FREE ticket at [www.renewables-roadshow.co.uk](http://www.renewables-roadshow.co.uk)



Reebok Stadium Bolton, 6th September | Ricoh Arena Coventry, 8th September |

HEADLINE SPONSORS: SPONSORS:





engineering must adapt. 'Clients care about energy, but don't know what to do for the best. Main contractors are in a tough, recessionary frame of mind at the moment – not surprisingly – so low-energy solutions must be low-cost too. The money to support this is in the lifecycle.'

The industry has a poor reputation for innovation, but Ford thinks that is unfair. The contractual process has not helped, and that is something the government can help to reform by being an enlightened client. Perhaps a qualification in 'clientology' should be required in the future, he says.

**Collaboration**

'For all its flaws, the Building Schools for the Future (BSF) programme had started to bring together expert teams whose knowledge could be replicated and applied to multiple projects – there was a contractual model there for creating teams, leveraging knowledge and replicating success. That has now all been discarded and the teams are fragmenting, but the government still has the problem of delivering an improved infrastructure for schools and colleges.'

'I don't believe that the piecemeal alternative now in place will do better – it might not cost as much, but will it deliver?'

This collaboration of skills and effort was very much in his mind when Fulcrum merged with Mott MacDonald. Putting Fulcrum's sustainability skills onto a larger platform should mean they can have a greater influence on projects. The employee-owned company is heavily involved in major energy and infrastructure projects, and urban planning, as well as smaller-scale building services technology.

Ford believes this is an evolving pattern with architectural practices, such as Fosters,

also seeing the need to integrate building services expertise into their teams.

CIBSE can be a big part of this evolution by working with other bodies to produce contractual frameworks for 'beyond integrated teams' to lifecycle businesses.

He believes we need a new delivery model for businesses without the traditional hierarchies and silos that hold back progress. Energy suppliers must also be part of this.

'Naturally, our focus is mainly on the demand side, but we will not reach our carbon reduction goals if utilities are not simultaneously forcing the pace on decarbonising the national grid,' says Ford. 'Again we have a tremendous amount to offer in terms of what renewables work best where, and in what parts of the built environment – more and more utilities are looking to our members for expertise.'

Ford sees CIBSE's willingness to share its experience of building energy certificates with its American counterpart ASHRAE as a good example of what collaboration can achieve on a global level.

'CIBSE has a role at many levels. We work locally and so have to deal with local planning issues; we work nationally so have a position on the UK's entire approach to carbon reduction across the built environment; and we work internationally with our worldwide members and like-minded partners.'

'From a business perspective, UK practices are looking abroad for work to compensate for the slow economy at home – but also because our work is global and there are big opportunities in growing overseas markets. Tackling global emissions has to be a global effort and it is also an opportunity to export British, and particularly CIBSE, expertise in this area.' **CJ**



**CV**  
**ANDY FORD**

---

**EDUCATION**

**1975-1983:** BSc (Hons) in Mechanical Engineering, Bath

---

**CAREER**

**Early career:** Student apprentice at diesel engine manufacturer R A Lister in Dursley, Gloucestershire

---

**1975-1983:** Works at Max Fordham and Partners

---

**1984:** Founds Fulcrum Consulting

---

**2009:** Fulcrum Consulting joins Mott MacDonald Group

---

**ACTIVITIES**

CIBSE president for this year

---

Chairman of the UK Green Building Council policy committee

---

Winner of the IMechE Construction and Divisional Prize 2009

---

Has sat on a wide range of government departmental project groups

---

CIBSE representative on the Construction Industry Council Forum for Research Innovation and Knowledge

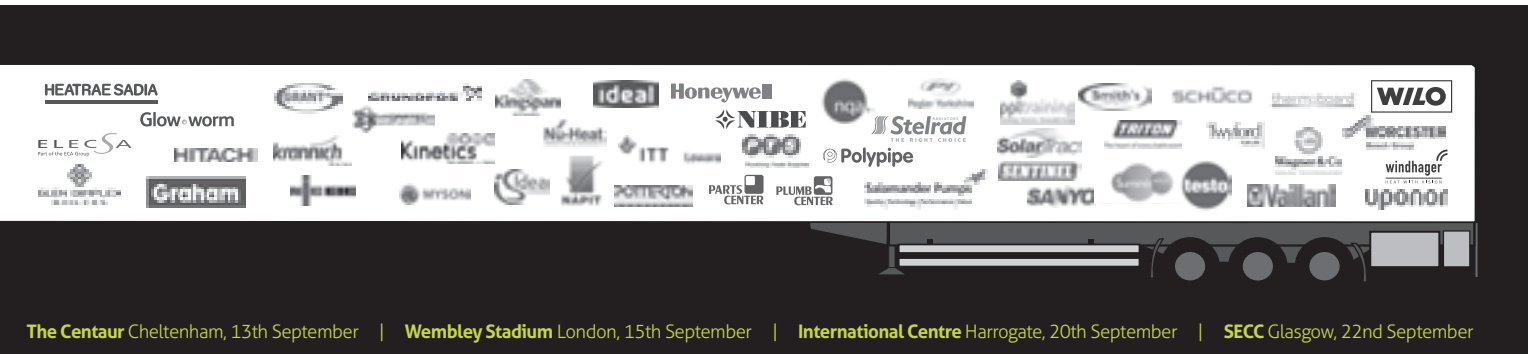

The Centaur Cheltenham, 13th September | Wembley Stadium London, 15th September | International Centre Harrogate, 20th September | SECC Glasgow, 22nd September

PARTNERS:



Qatar is an economic oasis in a harsh desert climate. Its latest construction challenge will be to host the first 'carbon neutral' football World Cup



# DESERT BLOOM

Qatar is forging ahead with sustainable development, one key example of which is the new Education City.  
By **David Baker** and **Jackie Portman**



**Q**atar's success in securing the 2022 football World Cup reflects the fact that the small Gulf state has enjoyed exceptional economic growth since the 1960s and has a forward-thinking approach to sustainability. The first 'carbon neutral' World Cup will be the next chapter of the state's development story.

Qatar, which sits on the largest gas field in the world, has gone through the classic stages of industrial development: from primary (extraction of gas) to secondary (expansion of industries derived from oil, gas and hydrocarbons) to tertiary (providing services to support the former) to embarking on the fourth stage, that of producing information and knowledge services. This fourth stage is exemplified by the Education City project.

Education City is located on the outskirts of the capital, Doha, and covers 15 sq km (about the size of five 18-hole golf courses). The project was started in 2002 and is expected to be completed in 2015. The capital build value is currently estimated at £1.0bn.

The project aims to be the centre of educational excellence in the whole of

the region. It will house a full range of educational facilities including schools, branch campuses of some of the world's leading universities, a teaching hospital, research facilities to encourage liaison between academics and industry, and the new Qatar National Convention Centre.

In addition there will be support facilities such as housing, retail, sports facilities and one of the World Cup football stadiums. The integrated transport network will include a driverless train system.

The client body is the Qatar Foundation for Education, Science and Community Development. The master plan for Education City was devised by the Japanese architect and RIBA Gold Medal winner, Arata Isozaki, who also designed a number of the existing buildings. More than one-third of the scheme has been completed, with final completion expected by the end of the decade.

Key strategic design philosophies included reducing CO<sub>2</sub> emissions, preserving the aesthetics of the development (roof-mounted plant is not allowed, for example), efficient space utilisation, and optimising energy usage. These criteria led to a strategy of seven

6 Providing the site infrastructure in such an arduous desert environment presented a formidable challenge to building services designers



Jackie Portman outside the Khalifa stadium, which is under consideration for the 2022 World Cup

► central plant areas distributing services to a number of localised buildings.

Providing the site infrastructure to support these facilities in such an arduous desert environment presented a formidable challenge to building services designers faced with temperatures rising to 50C, humidity of 100%, occasional sand and dust storms, very low rainfall, strong prevailing winds, and a coastal environment. Qatar has also set itself high sustainability goals through its National Vision 2030 programme, including targets to achieve LEED Gold and Platinum certification for its buildings.

Local water usage figures are some of the highest recorded worldwide. At Education City water is sourced as part of the power-generation process from desalination plants, and in part from the existing water table approximately two metres below ground level; despite the high levels of suspended solids and chloride as heavy metals and faecal coliforms existing at this level, this water is treatable by applying principles of reverse-osmosis.

Water used for domestic purposes and for irrigation and fire services is stored and treated in each of the seven central plants where 72 hours of storage capacity is provided in 500,000 cu m tanks (equivalent to about 200 Olympic-sized swimming pools).

A centralised district cooling system is provided from the central plants, each with a refrigeration capacity of 280,000 tons using 3.3kV chillers. The use of centralised

chillers, cooling towers and pumps makes district cooling work more efficiently than other systems, resulting in projected electricity savings of between 40% and 60% when considering unitary equipment. In addition, due to scarcity and cost of potable water, it was more practical and economical to treat and use sewage effluent for large district cooling plants for the cooling tower water make up supply than for smaller, scattered cooling plants.

Electrical power is derived from gas-fired power plants to accommodate an eventual maximum demand of 350 MVA spread over

11 66 kV sub-stations.

However, a solar farm is planned that will contribute to the electrical supply availability at Education City.

Education City houses two data centres, and a third is planned. Private fibre-optic campus backbone cables support a converged network carrying video data transmission, voice and

building management system traffic. A state of the art SCADA-driven command and control centre is planned to centralise control of these systems and also to include centralised facilities management services.

Utility services are distributed from the sub-stations and central plants in a network of more than 50 km of underground tunnels (typically 4m x 4m in aspect with 5m of cover) which run around the site and which are arranged so that the new buildings can connect into the valved services.

International consultants have largely been responsible for the design of the infrastructure. A number of UK consultants have been responsible for the design of buildings on the campus. The project is managed by Astad Project Management, which is a joint venture between Qatar Petroleum and Qatar Foundation.

As a country dominated by readily available prime energy sources, Qatar is catching up and embracing the challenges of global sustainability. It is trying to use its resources wisely with the next major challenge of delivering a carbon-neutral Football World Cup in 2022. **CJ**

6 As a country dominated by readily available prime energy sources, Qatar is catching up and embracing the challenges of global sustainability



## CIBSE Qatar group set to grow

The group, formed last year, has more than 40 members and this is expected to grow as the construction industry in Qatar continues to expand. Last year, CIBSE chief executive Stephen Matthews and CIBSE president-elect Andy Ford visited the group and presented an update of CIBSE strategies and aims.

The group offers a range of services including technical presentations, social events, advice for new and potential members, and schools and university liaison. It is



Paul Cowan/Shutterstock.com

also a focal point for the local enforcing authorities in developing their own standards and regulations.

Qatar is aiming to develop and train its own nationals to eventually reduce the reliance on expatriate workers. CIBSE Qatar fully embraces this and offers the necessary support to the Qataris.

● For more information, contact the chairman Michael Daly at michael.j.daly@aecom.com Details on the group are also available at [www.cibse.org](http://www.cibse.org)

● **DAVID BAKER** and **JACKIE PORTMAN** work for Qatar Petroleum's Special Projects Division, Astad Project Management



**VICTAULIC**  
**INSTALLATION-READY**  
**TECHNOLOGY**

*Up to 10 times faster to install than other joining methods.*



[www.victaulic.com](http://www.victaulic.com)  
 Units B1 & B2 SG1 Industrial Park  
 Cockerell Close  
 Gunnels Wood Road  
 Stevenage - Hertfordshire  
 SG1 2NB  
 Phone: +44 1438 310 690  
 Fax: +44 1438 310 699

NORTH AMERICA • UNITED KINGDOM • EUROPE  
 MIDDLE EAST • LATIN AMERICA • ASIA PACIFIC



**yes we can**

It's part of our philosophy as well as our name.



*Design, draw, supply and install. Our can-do attitude.*

When they said it couldn't be done, they obviously hadn't talked to Naco. No matter who in the industry suggests that what you ask for is impossible, it's always been our privilege to prove them wrong.

Unlike most UK louvre companies, we design, draw, supply and install. So not only do our products match your requirements precisely in terms of function but also in style, finish and colour. It gives architects and designers a unique opportunity to create a pleasing architectural ventilation feature or screening control within the external cladding. And it's this can-do attitude that creates so many satisfied clients.

For more information on how we can help with your next project please visit:

[www.naco.co.uk](http://www.naco.co.uk)

A brand of **Ruskin Air Management Limited**



Our ideas built with you in mind

**STOKVIS**  
 ENERGY SYSTEMS

Boilers

Plate heat exchangers

Pressure sets

Solar

# The Complete Solution

**Ecotube**  
Solar panels and vessels

**Stokvis** stand alone plant or **Heatpak** – complete packaged plantroom

**Econoflame**  
High efficiency and condensing premix boilers

**Econopress** and **Econoboost**  
Pressure and booster sets

**Econoplate**  
Packaged plate heat exchangers

For further information or to receive a technical guide: tel: 020 8783 3050 or email: [info@stokvisboilers.com](mailto:info@stokvisboilers.com)  
[www.stokvisboilers.com](http://www.stokvisboilers.com)



All images courtesy of Arup Associates



# SOCCKER SPECIAL

Qatar is not only demonstrating its ability to build football stadiums that will remain cool in desert conditions. The nation that is hosting the 2022 World Cup also has 'carbon neutral' design at the top of its agenda. **Andy Pearson** reports





Qatar's demonstration mini-stadium will be monitored to assess how the technologies used will perform in desert conditions. Applications include armour-like PVC scales covering the steel frame (far left) and extensive use of photovoltaic sheets (left)

It was a surprise for some when Qatar's bid to host the 2022 football World Cup was successful. In the desert state's hot and humid summers, temperatures typically average 44C, but the thermometer can nudge 50C.

The football world governing body, FIFA, has even warned of a risk of heat stress for players in conditions above 24C wet bulb globe temperature (WBGT), which measures humidity, solar and wind factors as well as temperature. But Qatar is used to dealing with the heat, and one of the reasons for its successful bid can be found in the desert, on the outskirts of the capital, Doha, in the form of a miniature stadium.

Constructed in just four months, the 500-seat Qatar Showcase stadium was built to demonstrate that a harsh desert climate need not be a barrier to hosting the World Cup. When a delegation from FIFA visited the little circular stadium, the temperature was a scorching 44C outside; yet inside, on the stadium's five-a-side pitch, it was a very pleasant 23C WBGT.

The significance of the Showcase stadium in the desert state's bid success is not simply that it was air conditioned: the country's

Al Sadd stadium already has a successful air conditioned pitch and stands. FIFA's remit to Qatar was 'to achieve the first carbon-neutral World Cup'. And so, according to its designers, the Showcase stadium stands as an example of a zero carbon development.

'This zero carbon, environmentally friendly, mini-stadium demonstrates that it is possible to provide comfort for football matches in the heat of the desert,' explains Mike Beaven, head of building services and environmental engineering at Arup Associates, the stadium's designer.

In addition to 'showcasing' these technologies, the stadium's other main purpose is to provide a facility to monitor the performance of the technologies under desert conditions. It is an important undertaking because Qatar has plans to incorporate low carbon technologies into the giant football stadiums planned for the World Cup. The three major components that will be investigated in the design of the stadium are: passive energy-saving architecture, solar-thermal cooling, and grid-connected, photovoltaic-generated electricity.

The stadium's architecture plays a critical role in ensuring comfortable conditions

The Showcase stadium is important because Qatar has plans to incorporate low carbon technologies into the giant football stadiums planned for the World Cup





The mini-stadium aims to show how conditions can be kept to mild temperatures for players on the pitch with the use of sustainable technologies

➤ on the pitch. During the day the pitch and stands are protected from the sun beneath a giant domed roof canopy. This is formed from hundreds of triangular, armour-like scales of PVC material stretched over a steel frame. The PVC has a low-emissivity coating to reduce re-radiation of the heat. The scales are arranged to form a series of shaded, north-facing openings to let heat escape from beneath the roof while allowing reflected daylight to bounce into the space. Beneath the canopy a blanket of pillows made of ETFE – a transparent polymer sheeting – provide thermal insulation to limit the amount of heat radiated by the roof. This helps to ensure that conditions remain within ASHRAE comfort standards for the spectators.

In the run-up to a match the roof will remain closed throughout the day to shelter the stadium from the burning sun and enable the stadium's cooling system to cool the interior effectively. FIFA rules state that World Cup games should not be played under cover. The Showcase stadium's roof is divided into two semi-circular halves: a fixed, western section and a movable eastern section, mounted on tracks. To open the roof, the eastern half is rotated until it nestles beneath the fixed section. Matches will be played in the evening, so the fixed section is designed to shield the pitch from late-afternoon sunlight and to offer some protection against strong desert winds.

Arup Associates has turned the country's climate to its advantage when it comes to keeping the stadium, players and spectators cool. Adjacent to the stadium is a giant solar farm, covering an area roughly twice that of the stadium itself. The farm contains a giant linear Fresnel collector formed from 44 strips of flat-plate mirrors. These 32m-long mirrors are motorised so that they can rotate around a single axis to track the sun. The mirrors are arranged into four groups of 11. Each group of mirrors is angled to focus

the sun onto a single vacuum absorber tube supported above the array. The tube contains water at a pressure of 16 bar. The high pressure enables the water to be heated by the sun to a temperature of to 200C without turning to steam.

The super-heated water is stored in a buffer tank before being pumped to a double-effect lithium bromide absorption chiller. Here it is used to drive water from the diluted lithium bromide solution as part of the absorption cooling process. The chiller produces water cooled to 6C.

To enable the solar-powered chiller's output to be stored until it is needed in the evening, the chilled water is piped to a 3.5m diameter, 12m long cylindrical storage tank buried below ground adjacent to the stadium. The water-filled tank is packed with eutectic blocks, measuring roughly 300 x 200 x 25mm. The blocks are filled with a material which freezes at 6C. The cooling is stored as latent energy in the material as it changes phase from liquid to a solid. When a match is under way, cooling energy is released back to the system as it returns to its liquid form.

---

Arup has turned the country's climate to its advantage when it comes to keeping the stadium, players and spectators cool

Once the store is fully charged it can provide up to five hours of cooling. 'The really good thing about this solution is that once the tank is charged, the chillers can stop but you've still got cooling,' says Beaven. Should the solar system fail completely, the designers have taken no chances and installed a conventional, standby chiller.

From the storage tank, the chilled water circuit connects to two air handling units (AHUs). One AHU serves the back of house areas with chilled, dehumidified air; the other serves the pitch area through grilles beneath the spectators' seats. The pitch is surrounded with a concrete structure to add to the stadium's thermal mass, to mitigate heat gain from spectators and floodlighting. As the cold air descends to the pitch it forms a reservoir of cooled air in the bowl of the stadium to keep the players cool.

The biggest threat to the design is the wind. On cool days the cold air is held within the stadium bowl. However, on windy days there are concerns that the desert winds

---

This zero carbon, environmentally friendly, mini-stadium demonstrates that it is possible to provide comfort for football matches in the heat of the desert

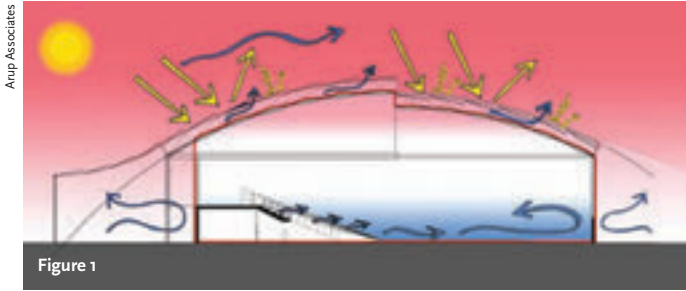

Figure 1

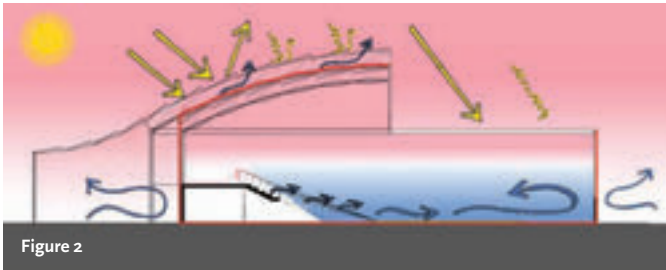

Figure 2

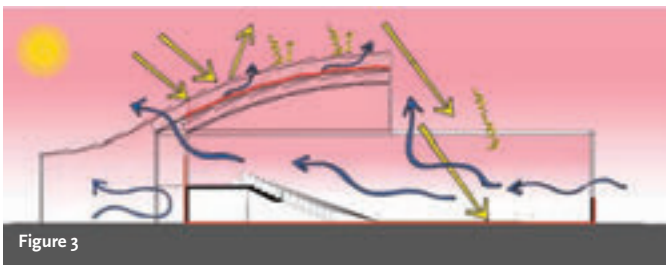

Figure 3

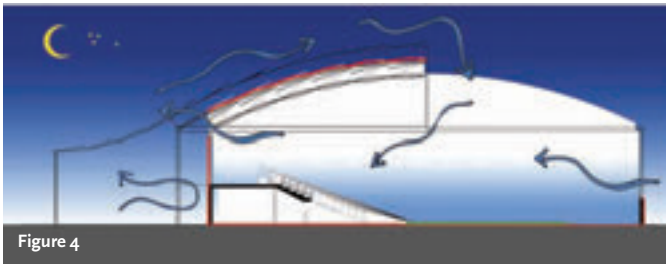

Figure 4

Four depictions of the expected flow of hot and cool air during day- and night-time conditions:

Figure 1

*Preparing for match – hot day:*

- Protection from direct sunlight and wind
- Diffuse light entry through north roof lights
- Underseat air supply

Figure 2

*During evening match – hot, still day:*

- Roof open (On a windy day the the roof will remain closed)

Figure 3

*Mild day (most of the year):*

- Roof and wall open
- Direct sunlight
- Entry openings for cross-ventilation

Figure 4

*Mild evening (most of the year):*

- Roof and wall open

will scour the chilled air from the stadium, exposing the players to untreated air. ‘We predicted that wind will be an issue,’ says Beaven. The extent of the problem, and finding appropriate solutions, is one of the areas that will be investigated further through monitoring actual performance of the Showcase stadium.

The final component of Arup Associates’ design is a giant photovoltaic (PV) installation, located adjacent to the Fresnel reflectors on the stadium’s solar farm. The PVs are connected to the stadium, from where they feed Qatar’s national grid. They will generate electricity year round from solar radiation. Games take place in the evening so the PV’s are of little use to power the stadium.

Instead, power for the stadium is imported from liquid biofuel-powered generators or it is drawn directly from the

Work is being undertaken to monitor the Showcase stadium’s performance, as well as that of the various low carbon technologies

grid. However, the amount of electricity generated from PVs over a year has been calculated to exceed the total amount of electricity imported on match days. This allows the stadium to be described as a ‘zero carbon’ facility, according to Arup Associates.

A curious part of electrical design is the inclusion of the biofuel-powered generators. According to Beaven, it is normal to power a stadium from generators to ensure certainty of electrical supply for critical matches. The electrical grid then acts as back-up should the generators fail. There is no shortage of gas to power generators in gas-rich Qatar. However, as FIFA is expecting Qatar to use ‘clean, renewable energy resources’. So the generators are biofuel-powered. Unfortunately, Qatar has no biofuel resources and will have to rely on importing ‘green’ fuel.

Work is being undertaken to monitor the Showcase stadium’s performance, as well as that of the various low carbon technologies, to see if they are appropriate to be integrated into the giant stadiums for the 2022 World Cup. Beaven is optimistic that Arup Associates is close to developing a suitable zero carbon solution: ‘This is a prototype; it can be improved and upscaled,’ he says. CJ

# CARBON CEILING

After the government unexpectedly watered down its commitment to introducing 'zero carbon' new homes, the future housing stock will be at best low carbon, writes Nigel Banks

**O**n taking office last year, the new government made clear in its 'coalition agreement' that it was committed to ensuring that all new homes would be 'zero carbon' from 2016. This was to be achieved by a combination of on-site 'carbon compliance' and 'allowable solutions', which together would offset all of the expected annual CO<sub>2</sub> emissions from a dwelling. The result would be a net-zero carbon home that would be equivalent to a dwelling built to Level 6 of the revised Code for Sustainable Homes (the Code's highest level).

'Carbon compliance' measures are those which are installed on the individual dwelling or directly connected to it, such as district heating. These measures are largely aimed at cutting 'regulated' energy use; that is, activities that come under the scope of the Building Regulations (space heating, domestic hot water, lighting, cooling and ventilation).

'Allowable solutions' were proposed in 2008 as a way to address unregulated energy use and also to help challenging sites offset all their remaining carbon emissions if this could not be done through carbon compliance alone. Allowable solutions enable these sites to offset their remaining regulated emissions, as well as those that are not subject to the Building Regulations – such as cooking and energy used by domestic appliances, which typically add another 50% to 100% to the regulated emissions. The proposed allowable solutions included fitting energy efficient appliances, investing in local low carbon energy infrastructure, retrofitting works to existing homes, and off-site renewable energy.

Last year I sat on the Carbon Compliance

Task Group of the Zero Carbon Hub, the cross-sector body set up to work with industry and advise the government. After six months' work and a number of consultation events, the Hub produced a report in February this year recommending appropriate minimum standards for on-site carbon compliance. The report proposed a minimum standard for all new low-rise homes, based on a reduction of regulated emissions of between 44% and 60% (depending on the type of dwelling) from 2006 levels. The remaining regulated and all the unregulated emissions could then be tackled through further reductions on site or via allowable solutions.

This was all reasonably clear but in March this year, in the 'Plan for Growth' document, published alongside the 2011 Budget papers, the government moved the goal posts on how the industry should define a 'zero carbon' home, making it clear that it agreed with the recommended carbon compliance levels. However, in a highly unexpected move, the document also indicated that carbon savings will not have to be made from cooking or unregulated plug-in electrical appliances (those not coming under the Building Regulations). The reason given is that emissions from these appliances will be offset via policies, including the EU Emissions Trading Scheme. However, carbon savings from cooking appliances are not covered by the scheme!

## Watered down

The effect of this apparent re-clarification of 'zero carbon' homes is to water down the Hub's original definition quite significantly. The change takes all unregulated emissions for cooking and appliances – which make up





around half of the emissions of a typical new home – out of the scope of the definition.

By changing the definition from a dwelling that is at Code Level 6 to one that is now effectively at Level 5, the government has more than halved the amount of carbon to be offset by allowable solutions; which means it has, at the very least, halved the funding that will be available to do ‘other works’, such as offsite wind power and local district heating. The Hub’s report estimated the cost of allowable solutions for a Code 6 home to be about £5,000 per dwelling for the full (Level 6) definition. With a Level 5 dwelling (which is what we have under the new definition), you would expect this to drop to around £2,500, hence a halving of funding for the kind of works described above.

However, Richard McCarthy, director general at the Department for Communities

An example of a house built to Level 6 of the Code for Sustainable Homes – a level considered to be truly ‘zero carbon’

and Local Government (DCLG) recently said at a housing conference that DCLG now expects the cost of allowable solutions per dwelling to be around £1,000. This figure came as quite a surprise as it also means that DCLG are expecting the cost of carbon for delivering allowable solutions to be lower than those set out by DCLG in the terms of reference of the Hub task group.

It’s true that this new definition of ‘zero carbon’ has not changed the carbon compliance levels that developers have to meet on site; the standards still involve an improved building fabric specification and a certain amount of renewable energy (or moving towards a Passivhaus specification without any renewables). But there is undoubtedly a big change in terms of how far developers have to go to offset non-carbon compliance emissions on site or through allowable solutions.

Even under the original definition it could have been argued that a dwelling would actually be ‘carbon neutral’ rather than ‘zero carbon’. As a result of the changes, homes will at best be only ‘low carbon’. The new definition of zero carbon is a bit like taking a return flight in a new, efficient aeroplane, offsetting your emissions at the airport but only offsetting one leg of the journey and arguing that the plane would have been coming back anyway!

### Pragmatic

It is true that the new definition of ‘zero carbon’ is seen by many in the industry as a sensible, pragmatic change, making it easier for developers to build more low carbon homes than they might have done under the original definition – and more homes are desperately needed. There is also the argument that, in a few decades’ time, when the grid is more fully decarbonised, then these homes could in effect become zero carbon.

There are, indeed, many pros and cons surrounding this decision. One concern is that the change will have an impact on the ability of new housing developments to cross-subsidise or part-fund other works, including, for example, community heating schemes. This reduction in funding will hit local authority programmes such as the upgrading of district heating systems and the retrofitting of existing dwellings.

Another concern raised by consumer groups is that there is a potential for people

The Zero Carbon Hub's adjusted slides illustrating the revised post budget definition of zero carbon homes. [www.zerocarbonhub.org](http://www.zerocarbonhub.org)

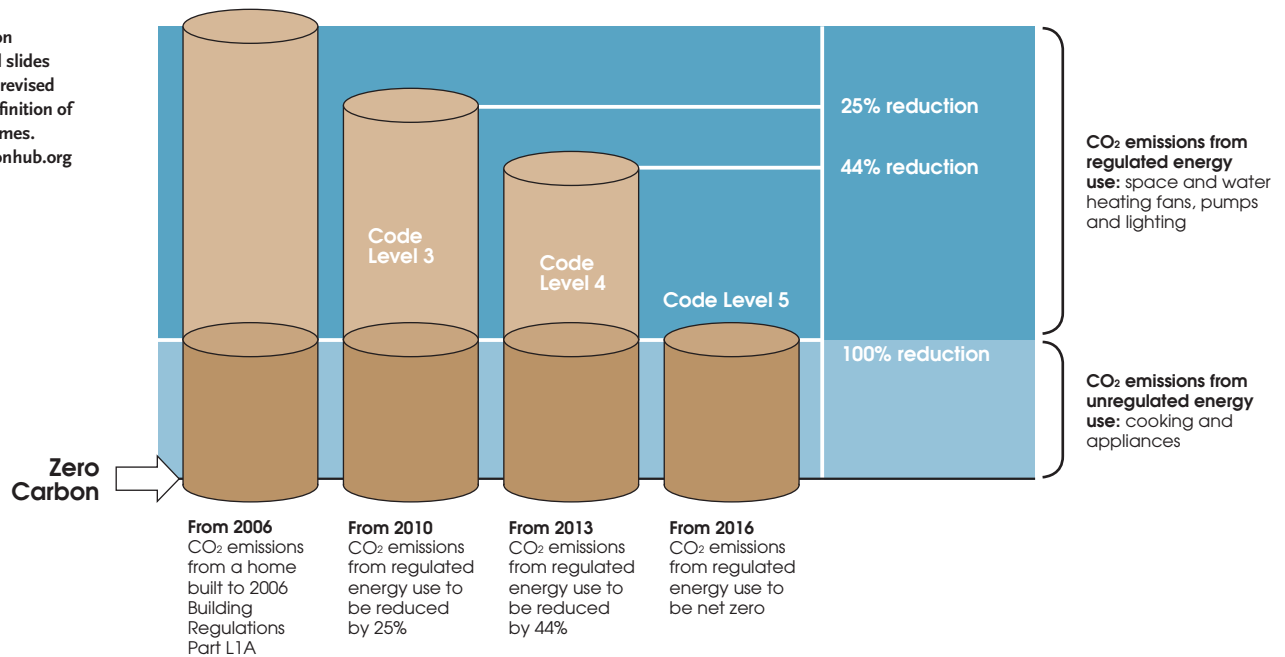

to think they are buying a 'zero carbon' new home with very low or no energy bills when they are getting, in reality, a low carbon home and are, in effect, having to fund off-site renewables in their local area, which may be of no direct benefit to them.

I believe the new definition of 'zero carbon' could also sap the overall ambition of the industry to invest time and money in developing innovative and cost-effective solutions to make significant emissions reductions. The industry has moved ahead in leaps and bounds on the back of the zero carbon homes ambition. A lot of work has been done to trial Level 6 homes to see how they can be built well and cost effectively, so that these lessons can be taken on board for all the homes to be developed in the future.

Just as it has become viable to take on the additional cost of delivering genuine zero carbon homes – thanks to feed-in tariffs and the Renewable Heat Incentive – most

developers will not be looking to build higher-performing homes. The high levels of innovation that have recently put Britain at the forefront of research and development in this area in Europe will diminish.

In response to the moving of the goal posts on zero carbon homes, the official line from the Hub was pragmatic and diplomatic. But the way this decision was taken without any consultation has certainly upset the apple cart, with WWF immediately resigning from the compliance task group. The whole idea of bringing the industry together to produce a recommended level of carbon compliance, and then government coming out with a different view without any consultation, was a great surprise to the Hub.

The Hub must now move forward and confirm the final piece of the 'zero carbon' definition as soon as possible. There will still need to be a lot of discussion around the issue of allowable solutions, even though the amount of carbon to be offset on site is considerably lower. How this approach to allowable solutions is going to be made to work in practice is something that will need a great deal of work by the Hub new task group and those across the industry represented on it. That is our task for the coming months. **CJ**

*CIBSE provided financial support for the work of the Hub's Carbon Compliance Task Group.*

**NIGEL BANKS** works for housing developer and community regeneration company Keepmoat, which is to complete the construction of its 100th Code 6 zero carbon home this summer. [www.keepmoatgreensolutions.com](http://www.keepmoatgreensolutions.com)

SSE's Greenwatt Way, a 'true' zero carbon home development built by Keepmoat



Keepmoat



# Discover a world of possibilities

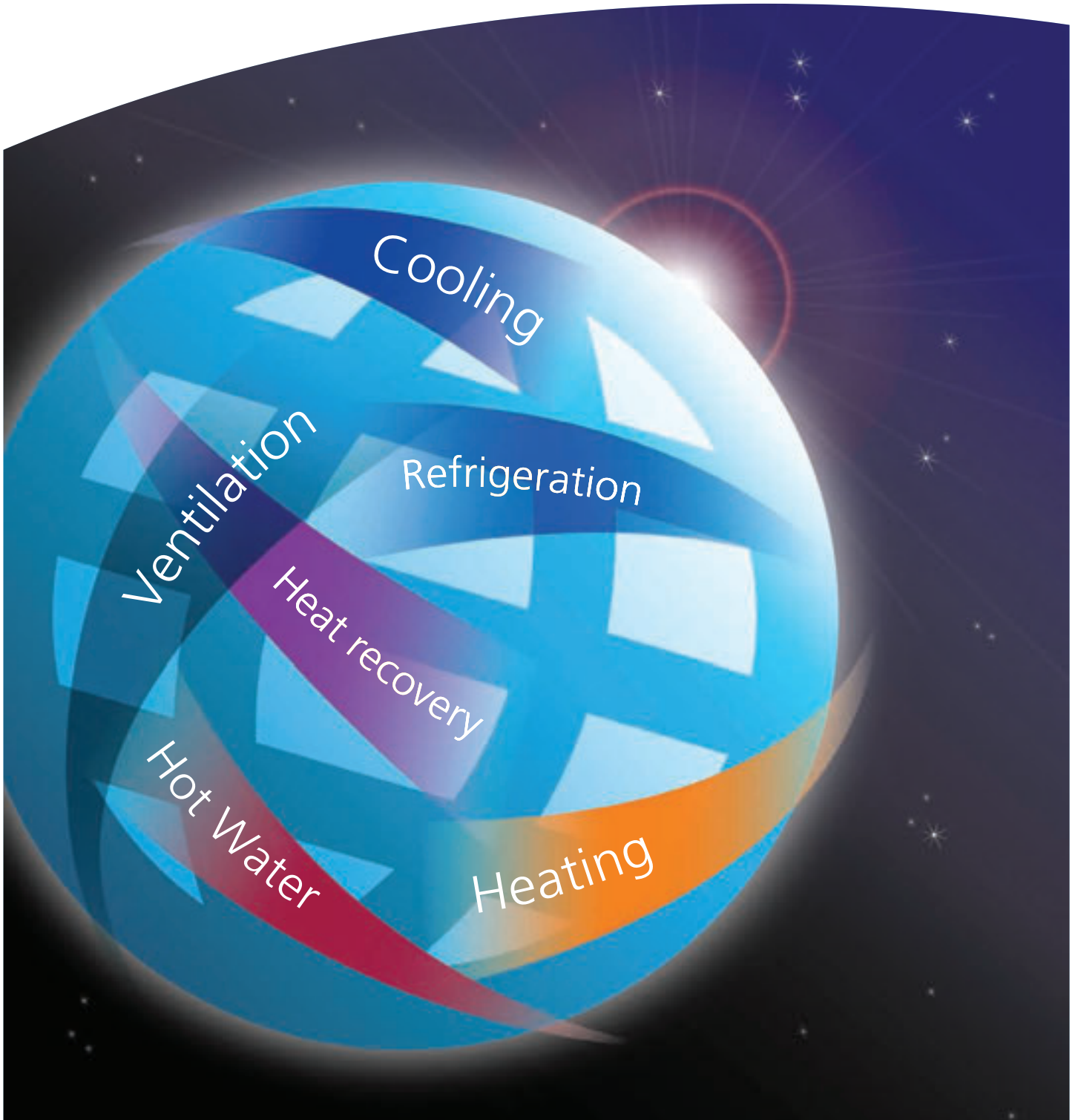

VRV systems offer a whole world of possibilities for energy efficient heating, cooling, refrigeration and heat recovery. Whatever the application, innovative and versatile VRV solutions are now available that can dramatically improve the energy performance of buildings. To reduce running costs and carbon emissions in every kind of environment, discover the true capabilities of the latest VRV<sup>III</sup>® solutions.

Discover Our World at [www.daikinourworld.co.uk](http://www.daikinourworld.co.uk)  
Email [rvv@daikin.co.uk](mailto:rvv@daikin.co.uk) or visit [www.daikin.co.uk](http://www.daikin.co.uk)

your comfort. **our world.**

Scotland Region	Northern Region	Midlands Region	Western Region	North London	South London
0845 641 9330	0845 641 9340	0845 641 9370	0845 641 9320	0845 641 9360	0845 641 9355



# COOL IDEA

A new process shows how it is possible to use natural ventilation in tandem with both heat recovery and cooling, writes **Morten Stender Christensen**

**N**atural ventilation has potential obvious advantages, which include low electricity consumption and installation costs. It is also often the preferred option from an architectural point of view, since suspended ceilings are not required. But because of low driving pressure available when using natural ventilation, it was not possible to find a commercial solution on the market that recovers the heat from the outlet air and precools the inlet air.

However, a new concept has been developed that has been shown to provide such a solution: natural ventilation with heat recovery and cooling (NVHRC). The concept has been developed jointly by Esbensen Consulting Engineers, the Danish Technological Institute, Aalborg University/Danish Building Research Institute and Danish ventilation systems manufacturer IKM, with the support of the Danish Energy Agency.

NVHRC makes it possible to recover the heat in the outlet air from natural ventilation and use it for space heating, preheating of the intake air and (pre-) heating of domestic hot water. Moreover, it is possible to precool the intake air and, for example, use the extracted heat from the cooling process for heating domestic water. (See Figures 1 and 2.)





**Heat recovery using NVHRC**

An air-to-liquid tube heat exchanger is placed in the air outlet within a room. The heat exchanger has a very low pressure drop on the air side – <5Pa at maximum air flow – due to the special design of the tubes. An axial fan provides backup when the natural driving pressure is insufficient.

A fluid with a temperature of 5C to 10C circulates through the tubes of the heat exchanger and cools the outlet air. The fluid is connected to a heat pump, which cools down the fluid and transfers the heat to the building’s heating system – from where it is distributed to provide space heating, domestic hot water and preheating of the inlet.

The potential heat recovery from the discharge air and the requirement for heat in the room or building, may not always match. On especially cold days, when the

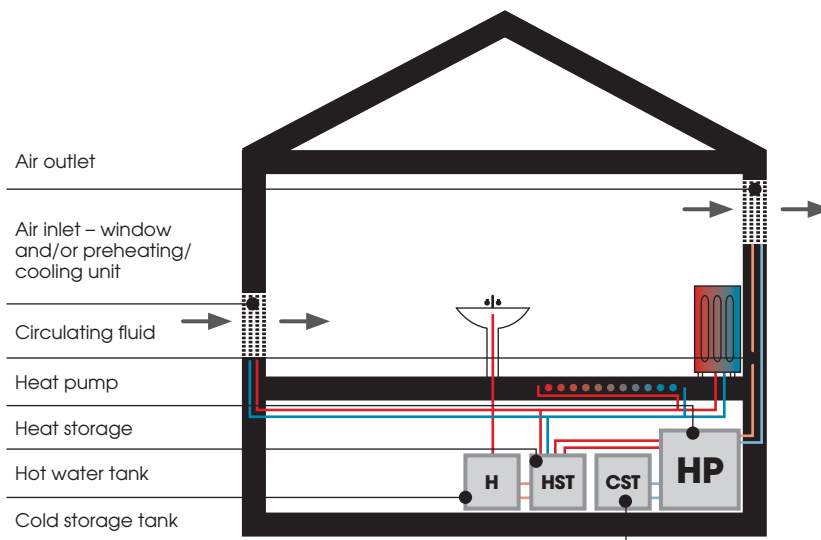

Figure 1: An example of heat recovery with NVHRC

■ HEATING

■ COOLING

■ HEAT RECOVERY VENTILATION



**Air Conditioning / Heat Pump Specialists Celebrating 30 years as a Daikin Distributor**

Space Airconditioning plc supports the entire range of energy efficient Daikin solutions.



Chillers, Split, VRV, Rooftops,  
R22 replacement, Spare parts and more!



Call: 01483 504 883

NOBODY KNOWS DAIKIN BETTER

www.spaceair.co.uk

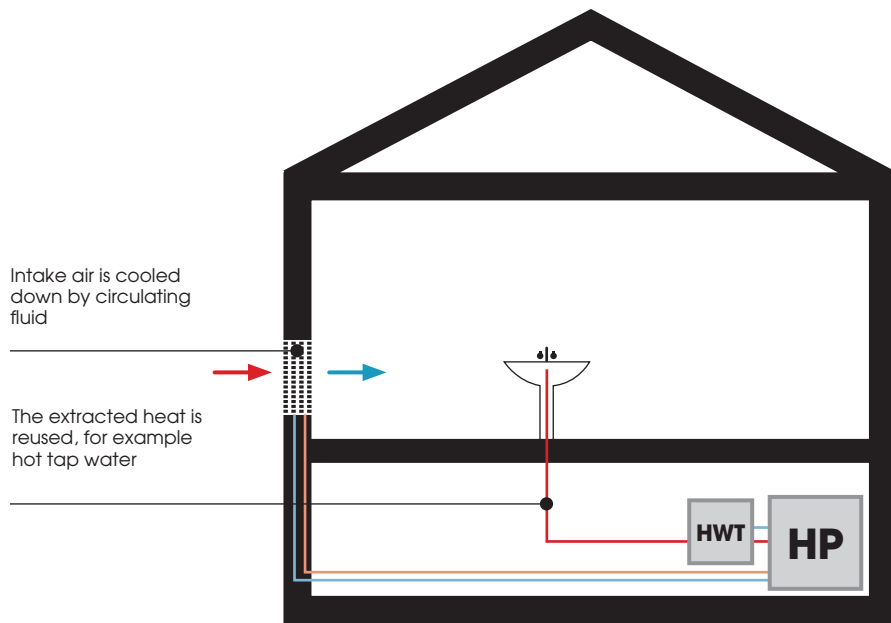

Figure 2: An example of sustainable cooling with NVHRC

➤ outdoor temperature is below freezing, the room will have a net heat demand, since there is an insufficient heat potential in the outlet air to heat up the room. Where the outside temperature is cool (5C to 10C) there may be more heat potential in the outlet air than is needed for heating the room, and the surplus heat can be used in other parts of the building. (See Figure 3.)

The idea of using a heat pump to extract heat from the outlet air is, of course, not new. Typically, mechanical exhaust and ductwork is used for ventilation; a heat exchanger placed in the discharge

Natural ventilation is considered to have many potential advantages over commercially used air conditioning, pictured below

Required area of air outlet	
Type of room or building	Required area of air outlet per 100 sq m net floor area
Office	0.2
Meeting room	1.0
Reception	0.4
Auditorium	1.0
Restaurant/cafe	1.0
Sports hall	0.4
Classroom	0.6
Common room	0.2
Kindergarten	0.5
Bank	0.4
Bakery	0.9
Dance hall	0.3
Exhibition hall	0.1

Figure 3: Estimated required size of the air outlet for various building types

airstream, via a heat pump, transfers heat to the heating system. But in NVHRC, natural ventilation is used, eliminating the electricity consumption for mechanical exhaust.

**Sustainable cooling**

If the room requires cooling, the cold circulating fluid can be directed to an air intake unit. The fluid will cool down the intake air, and the heat extracted by the heat pump from the circulating fluid can be transferred to meet coincident heating system requirements. The heat will usually ➤

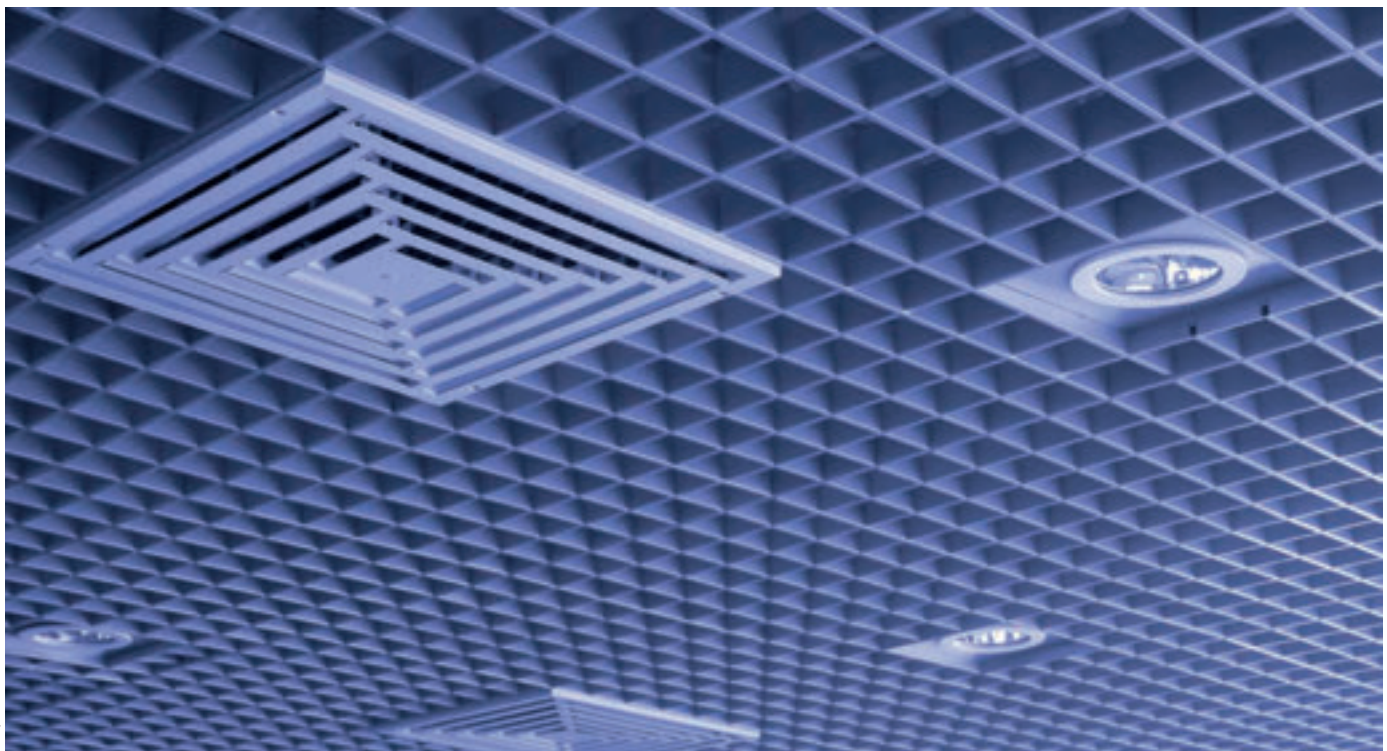



# KX6 Innovative VRF Technology



## 3D Scroll Compressor

This exclusive MHI technology realises greatly enhanced levels of energy efficiency and durability by 3-dimensional compression of the refrigerant, both radially and axially.

## Vector Inverter Control

Energy efficiency is enhanced further with MHI's new Vector Inverter control technology that enables optimum comfort control and ultra efficiency at low load.

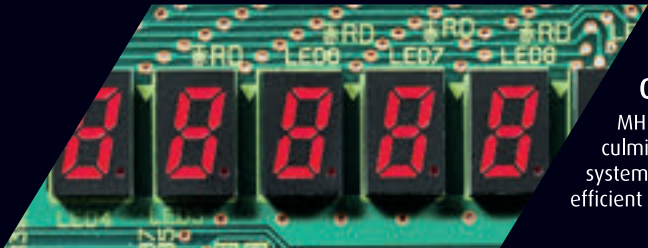

## Optimised Refrigerant Control

MHI's 100 years of refrigeration engineering culminates in our most efficient refrigerant control system, optimised to deliver consistent, energy efficient performance.



evolution

**amp air conditioning limited**

Tel: 01707 378670 Fax: 01707 378699, [sales@ampair.co.uk](mailto:sales@ampair.co.uk), [www.ampair.co.uk](http://www.ampair.co.uk)

**HRP Limited**

Tel: 01359 270888 Fax: 01359 271132, [headoffice@hrpltd.co.uk](mailto:headoffice@hrpltd.co.uk), [www.hrponline.co.uk](http://www.hrponline.co.uk)

**3D Air Sales**

Tel: 01753 495720 Fax: 01753 495721, [sales@3dair.co.uk](mailto:sales@3dair.co.uk), [www.3dair.co.uk](http://www.3dair.co.uk)

Scotland Tel: 0141 777 5007, Ireland Tel: 00 353 (0) 1463 8604



Figure 4: Net energy consumption for a nursery home common room

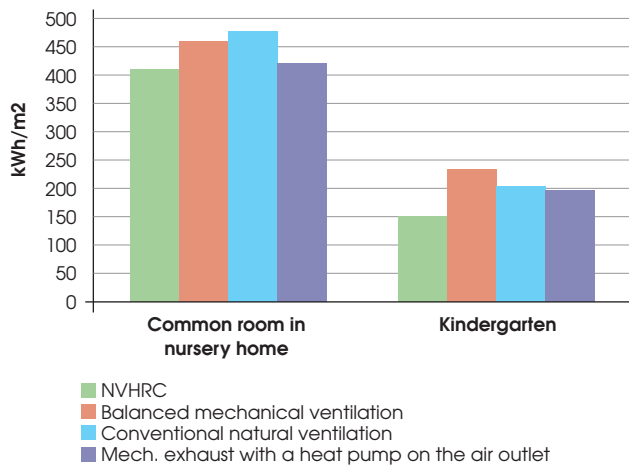

Figure 7: Operational costs for the sports hall and office

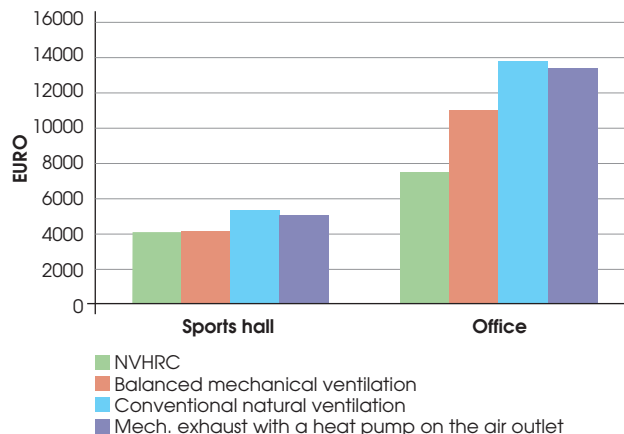
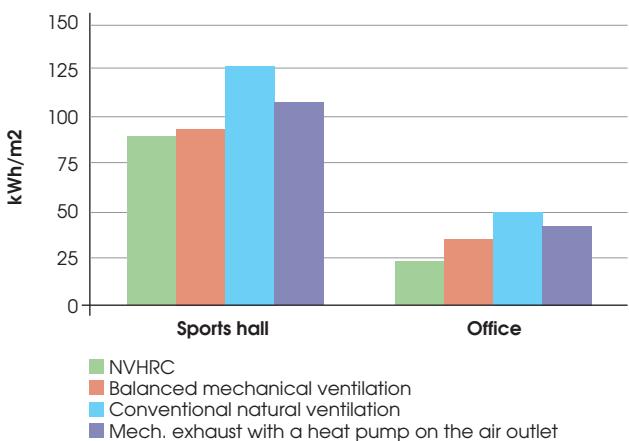

Figure 5: Net energy consumption for a sports hall and an office



► have been used for domestic hot water needs, unless there is a need to provide both space heating and cooling in the same building.

When using conventional cooling (without a heat pump), the extracted heat is often released without being used. With NVHRC, the extracted heat from the cooling process is considered a resource rather than a by-product. Instead of cooling the intake air, a chilled ceiling,

• NVHRC makes it possible to recover the heat in the outlet air from natural ventilation and use the extracted heat from the cooling process for heating water

Figure 6: Operational costs for the nursery home common room

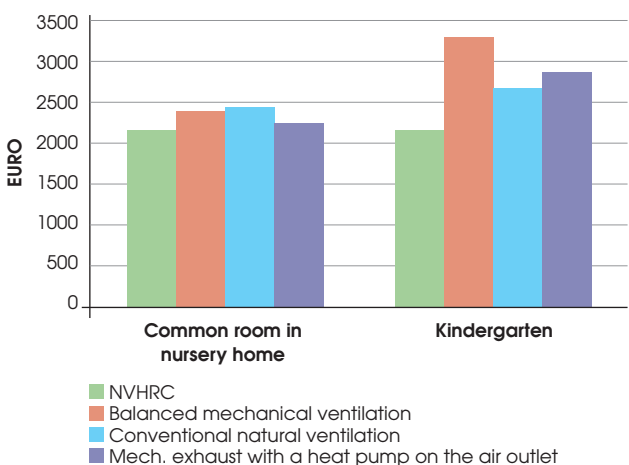

chilled beams, embedded pipe systems, or split units could be used. The research undertaken for this project found that 25% to 100% of the heat extracted from the cooling process can be re-used for heating.

**Energy savings**

The research project has also calculated example capital and operational costs of NVHRC on the basis of four types of buildings or rooms (in Denmark): a common room in a nursery (77 sq m), a sports hall (645 sq m), a kindergarten (200 sq m) and an office building (4,200 sq m). These calculations have been applied separately for NVHRC, balanced mechanical ventilation, conventional natural ventilation and simple mechanical



## All the benefits of VRF, without the price tag

### All the flexibility of VRF

Individual indoor unit control with an increased number of twin, triple and quad combinations.

### Seasonal performance

The optimised refrigerant circuit increases seasonal COP for heating and seasonal EER for cooling by 4%.

The award-winning Utopia is an excellent choice for twin, triple and quad combinations. As well as compressor optimisation for part-load efficiency, IVX offers increased comfort at reduced cost for every season. Improved connectivity on the IVX Series (4-6HP) and more flexibility (with 90-115% diversity) provides a great advantage, as well as the capacity to accommodate a greater combination of individually-controlled indoor units. Available with heating and cooling capacities from 5kW to 33kW, the new optimised models include the 5kW-16kW versions.

**Utopia gets into all the right zones, without the cost of VRF.**

### An efficient multi tasker

With further refinements to the DC inverter compressors and fan motors for increased efficiency even at low speeds.

### Great comfort

Features like cold draft prevention, frost protection, low noise and reliability are second to none, and available as standard.

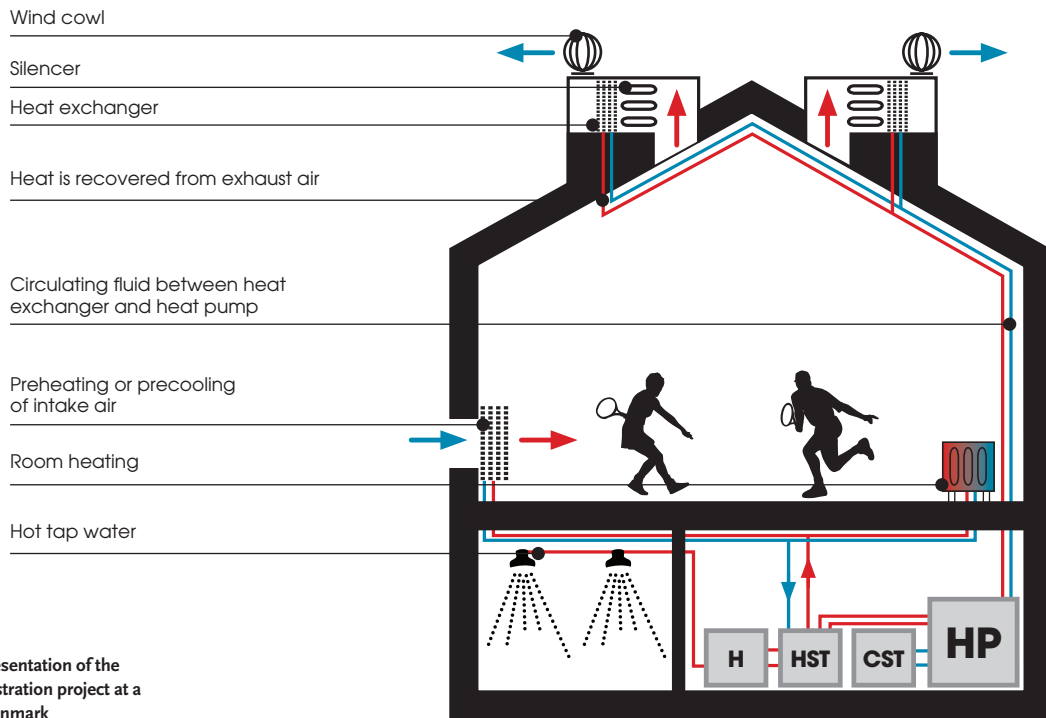

Figure 8: A representation of the NVHRC demonstration project at a sports hall in Denmark

➤ extraction with a heat pump on the air discharge.

The net energy consumption has been calculated in line with the Danish building regulations, where electricity is weighted as being 2.5 times as expensive as heat. In all four building types, NVHRC had the lowest net energy consumption (see Figures 4 to 7). These examples show that projected energy savings of up to 50% appear to be possible with NVHRC. The key reasons for this are:

- NVHRC uses mainly natural driving forces for ventilation. As previously mentioned, an axial fan is used for backup ventilation on days with low natural driving pressure, but it uses very little energy: an estimated 0.03 to 0.07 kJ/

cubic metre when in use. With balanced mechanical ventilation, the usage is estimated at 1.8 to 2.1 kJ/cubic metre.

- The operational coefficient of performance (COP) for the heat pump has been calculated at an impressive 4 to 5.
- The heat from the outlet air is also recovered in summer time (in Denmark), mainly for heating domestic water.

An electricity price of 0.2 euro (£0.16) per kWh and a price of heat at 0.07 euro (£0.06) per kWh have been used in the calculations.

The full results of the research project are available at [www.nvvc.dk](http://www.nvvc.dk), (available only in Danish).

As the above shows, the concept of heat recovery from discharge air in mechanical ventilation systems is not a new one; however, this solution provides the benefit of recovering the heat that would otherwise be lost through natural ventilation.

Using low pressure loss heat exchangers in the natural ventilation discharge, in combination with heat pumps, the system allows the building to maintain a more effective energy balance and shows potential to reduce its energy costs and lifetime operational carbon footprint. CJ

## Demonstration project shows benefits of NVHRC

A demonstration plant has been set up in a sports hall in Fynshav, Denmark. Figure 7 shows the plant running in heat-recovery mode, with air going via intake units in the facade. The units are capable of both preheating and precooling the inlet air.

Wind cowls placed on the rooftop draw air out of the building. A heat exchanger placed just before the wind cowl cools down the exhaust air, and a circulating fluid

transfers the extracted heat to the heat pump in the basement. From here the heat is distributed to the heating system.

The circulating cold liquid can also be re-routed to a cold water storage tank, which can be cooled down to 10C. The cold water from the tank can be used for cooling the intake air.

The ventilation capacity of the plant is up to 8,000 cu m/h. The heat pump has a maximum of 25 kW thermal.



The air handling unit on the demonstration plant

• **MORTEN STENDER CHRISTENSEN** is formerly of Esbensen Consulting Engineers, [www.esbensen.dk](http://www.esbensen.dk). For more information, please contact Tommi Haferbier Nielsen at [thn@esbensen.dk](mailto:thn@esbensen.dk). This article first appeared in *REHVA Journal*, [www.rehvajournal.com](http://www.rehvajournal.com)



Say goodbye to flanging, threading, pipe grooving and welding with:



## Axilock-S

Join plain end pipe with Teekay Axilock-S  
Seals and locks the pipes together  
**Two Pipes... Two Screws... Two Minutes**



tel: +44 (0)1494 679500

[www.teekaycouplings.com](http://www.teekaycouplings.com)



## Time is money!

**Timed deliveries available across the UK for all your air conditioning and refrigeration solutions.**

Extensive stock of complete systems, ancillary packages accessories and tools available for collection or timed delivery from branches across the UK including: Aberdeen, Glasgow Gateshead, Manchester, Birmingham, Heathrow Crayford and Fareham.

**kooltech**

0141 883 0447



[www.kooltech.co.uk](http://www.kooltech.co.uk)

## Better buildings with ENER-G



Build better and smarter with ENER-G. We can design, install, maintain and finance efficient Combined Heat and Power systems from 4kWe to 10MW, this is coupled with a range of energy efficient solutions.

Contact us for feasibility and design support and share our experience.

**ENER-G Combined Power Ltd**

T: 0161 745 7450

E: [chp@energ.co.uk](mailto:chp@energ.co.uk)

[www.energ.co.uk](http://www.energ.co.uk)





**jaga**

## Look below the surface...

CIBSE-certified  
CPD seminar on Facade  
Heating now available.  
Please contact us to  
book.

Unique 30yr guarantee  
on heat exchangers

GUARANTEE  
30  
YEAR  
HEAT EXCHANGER

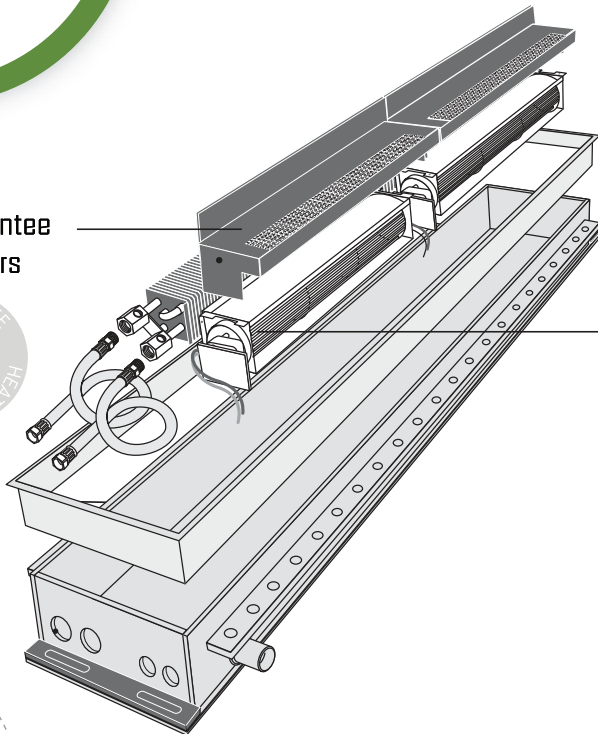

The only manufacturer with  
wooden, aluminium, stainless  
steel and designer grilles

See why, pound-for-watt, Jaga  
offers the best value in facade  
heating. Jaga has a ready  
solution for every trench  
heating application, even  
shallow floors, curves or  
odd-shaped corners.

Natural and dynamic fan-assisted  
heating options available

Supplied pre-assembled ready to  
drop into position

Delivery times typically less than  
four weeks

Factory tested to 20 bar

Jaga Heating Products

t: 01531 631 533

f: 01531 631 534

e: [jaga@jaga.co.uk](mailto:jaga@jaga.co.uk)

[www.jaga.co.uk](http://www.jaga.co.uk)

# Professional development

## The CIBSE Journal CPD Programme

Members of the Chartered Institution of Building Services engineers (CIBSE) and other professional bodies are required to maintain their professional competence throughout their careers.

Continuing professional development (CPD) means the systematic maintenance, improvement and broadening of your knowledge and skills, and is therefore a long-term commitment to enhancing your competence. CPD is a requirement of both CIBSE and the Register of the Engineering Council (UK).

*CIBSE Journal* is pleased to offer this module in its CPD programme. The programme is free and can be used by any reader. This module will help you to meet CIBSE's requirement for CPD. It will equally assist members of other institutions, who should record CPD activities in accordance with their institution's guidance.

Simply study the module and complete the questionnaire on the final page, following the instructions for its submission. Modules will be available online at [www.cibsejournal.com/cpd](http://www.cibsejournal.com/cpd) while the information they contain remains current.

You can also complete the questionnaire online, and receive your results by return email.

## Commissioning processes for heating and cooling water distribution in buildings

The latest regulations emphasise the need to commission building services appropriately. So, when should commissioning start and what should it involve? This CPD gives an overview of the process and focuses on specific examples

The complexity of building services solutions frequently expands to meet the demands of the increasingly stringent requirements of regulations and of local authorities. Building systems are proved in concept and their theoretical performance marked by their asset rating (in the UK by the Energy Performance Certificate, EPC) as calculated during the design process. However, the key measure is their effectiveness in use, as might be measured by an operational rating (and demonstrated by a Display Energy Certificate, DEC, in the UK).

The operational effectiveness will depend not only on the ingenuity and skill of the design and installation but, importantly, on the ability to set the systems to work properly. This commissioning activity provides an important link between the aspiration of the EPC and the actuality of the DEC. So important is the need for suitable commissioning that the Approved Documents for the 2010 revisions to the Building Regulations require that building services be appropriately commissioned, and that this should be done in a planned way and formally recorded, so that there is

evidence that the systems operate in line with the design intent.

This CPD article will look at the required commissioning processes of the one service that is included in virtually every building: water distribution for heating and cooling circuits.

### The formalisation of the need for commissioning

The Building Regulations require that it must be properly demonstrated to the BCB (building control body, a local authority or approved inspector) that the heating and hot water systems have been adequately commissioned. The term 'commissioning' includes the processes of bringing the systems into operation; their regulation; the setting up of associated control systems; plus the recording of the final settings and the state of the final system performance.

The actual commissioning process should start well before the building systems are installed, with a commissioning plan submitted at the design stage at the same time as the Target Emission Rate (TER)/Building Emission

Rate (BER) calculations are produced. As well as ensuring that commissioning is properly integrated into the process, this will allow the BCB to check that commissioning is being undertaken as work proceeds. It will also help to ensure that provisions specifically included for commissioning purposes do not fall foul of value engineering exercises, and are not neglected due to poor understanding of the commissioning needs by site personnel.

At the end of the commissioning process the BCB must be formally advised (within a prescribed time period) that the commissioning plan has been followed and that the results of tests confirm that the performance is reasonably in accordance with the actual building design. If the installed systems deviate from what was proposed at the time of design, then the alterations must be detailed in the report to the BCB. And until this commissioning notice is received, the building cannot be signed off as complying with the Building Regulations, so a delay in the formal commissioning processes may have significant implications on the issuing of a final completion certificate. ➤

Stage	Activities	Lead role	Support role	End date	Comments
Pre-construction	Ensure that the commissioning information included in tender documentation is clear, complete and fully coordinated.				
	Participate in the tender phase meetings to clearly communicate all information relating to the commissioning process.				
	Assist with the selection of construction specialists to ensure that commissioning requirements will be met.				

Figure 1: Pre-construction stage activities from BSRIA Model Commissioning Plan. Source: BSRIA BG8/2009

➤ The approved document to the England and Wales regulations notes that it would be 'helpful' if the notifications made to the BCB were signed by a suitably qualified person as from the Commissioning Specialists Association or the commissioning group of the Heating and Ventilating Contractors Association (HVCA).

The use of templates as outlined in the Model Commissioning Plan (BSRIA BG 8/2009) is recommended for documenting the process in an appropriate way. Not only do the templates provide a checklist of the required stages of activity, but they also ensure that the responsibility for that activity is clearly identified and signed off by the appropriate building professional. The principal stages identified are preparation, design, pre-construction, construction, commissioning of engineering services, pre-handover, initial occupation and post-occupancy (with each being subdivided into a number of activities). An example of one of the stages, pre-construction, is given in Figure 1.

### CIBSE Commissioning Code M

Whether by a sub-contractor or a specialist firm, the actual commissioning must be carried out in accordance with approved procedures in CIBSE Commissioning Code M: Commissioning Management. This Code provides an overview of the management arrangements required to ensure that building services systems are commissioned to meet the objectives of the relevant parts of UK Building Regulations (as described in AD Part L for UK and Wales). The Code is intended as a guide to good practice to enable the development of appropriate procedures and specifications aimed at developing a whole team approach to project commissioning. It does not contain specific detail on procedures for particular types of installations; these are provided in the CIBSE Commissioning Codes specific to the technology. (These are Code A: Air distribution systems; Code B:

Boilers; Code C: Automatic Controls; Code L: Lighting; Code R: Refrigerating Systems and Code W: Water Distribution Systems).

And although much of the content of Code M is generic, it lays out an underlying structure for the commissioning cycle that is then contextualised in the detailed technology codes. It provides some clarity by defining terms used in this work in an attempt to avoid misunderstandings.

Fairly commonly interpreted terms such as 'balancing' and 'regulation' are succinctly defined. Potentially more contentious terms that may not be universally understood by professionals are also given. One example of this is 'static completion', defined as: 'The state of a system when it is installed in accordance with the specification, i.e. clean and ready for setting to work. In the case of water systems this includes flushing, cleaning, pressure testing, filling and venting.'

Code M outlines the management of the whole process, from the need to set up the commissioning systems, programmes and teams early in the project; through

the design and co-ordination of commissioning; the actual commissioning and proving of the systems; and the need for proper recording, certification and handover. A particularly helpful appendix, 'Example responsibility matrix', provides guidance on the responsibilities that are likely to be taken by the various building professionals. (Four of the 17 example responsibilities are shown in Figure 2.)

The practices and delineation of responsibilities in a building project may well have shifted in the eight years since Code M was published. However, the core underlying requirement for the activities remains.

### Commissioning Code W for Water Distribution Systems 2010

CIBSE updated its Commissioning Code W for Water Distribution Systems only a few months ago. This code describes the requirements for balancing and commissioning water distribution systems, and is complemented by BSRIA Guide BG2/2010 Commissioning Water Systems, which gives the more detailed procedures in a step-by-step format. (Both documents potentially are needed to properly plan and execute the commissioning process.) The scope of both documents relates to the circulatory systems associated with heating and cooling systems.

Code W 2010 replaces the 2003 edition of the code, but maintains the same principal numbering systems to broadly accommodate any existing standard

Activity number	Activity description	Commissioning management organisation (CMO)	Building services contractor (BSC)	Main contractor (MC)	Consulting engineer (CE)
1	Review design drawings and specifications for commissioning requirements	Action and advise CE. Coordinate any comments from BSC and MC.	Advise MC of any comments.	Liaise and assist all parties.	Review comments and action as appropriate.
2	Review installation drawings and technical submissions from BSC for commissioning requirements.	Action and advise MC/CE.	Prepare and submit for review. Action any comments as instructed by MC.	Coordinate, supervise and direct/instruct as appropriate.	Review, comment and issue directives to MC if applicable.
3	Review installations with respect to compliance with specifications and drawing intent for commissioning.	Supervise inspection of installations, and issue reports to MC.	Receive CMO reports, and action as necessary.	Coordinate, supervise, and direct/instruct as appropriate.	Review, comment and issue directives to MC if applicable.
4	Production of detailed coordinated commissioning programme, including revisions and updating.	Procure information from BSC. Prepare programme, discuss with MC, and issue to all parties for comment.	Submit information, and liaise with CMO.	Review programme with regard to impact on construction process. Issue comments and approve.	Review, comment and accept.

Figure 2: Part of example responsibility matrix. (Source: CIBSE Commissioning Code M)



Component	Tolerance
Forced convection (fan driven) heating coils where flow rate is $\geq 0.015$ l/s and $< 0.1$ l/s: Heating water $\Delta T \leq 11^\circ\text{C}$ Heating water $\Delta T > 11^\circ\text{C}$	$\pm 15\%$ $\pm 10\%$
Forced convection (fan driven) heating coils where flow rate is $> 0.1$ l/s: Heating water $\Delta T \leq 11^\circ\text{C}$ Heating water $\Delta T > 11^\circ\text{C}$	$\pm 10\%$ $\pm 7.5\%$

**Figure 3: Partial excerpt of suggested tolerances when commissioning heating systems.**  
(Source BSRIA Guide BG2/2010; CIBSE Code W)

specifications that make explicit reference to sections of the code. The 2010 version contains guidance that has been updated to reflect the changes in practices and equipment. The revision was particularly prompted by the need to clarify and consolidate the guidance for variable flow systems that, as variable speed pumping control has dropped in capital cost, have become increasingly frequently applied in commercial applications. The difficulties of commissioning systems operating at very low flow rates (such as fan coil units) are also tackled in the revised edition.

Code W provides context to the generic guidance from Code M, although many of these areas (including definitions and process management tasks) are common across the different building services systems. Although most of the detailed practical advice is also provided by BG2/2010, there are particularly notable specific areas of detail covered in Code W, such as ‘pre-commissioning checks’, ‘setting pumps to work’, ‘balancing and regulating water flow rates’ and ‘commissioning documentation’. However, much of the detailed guidance that is contained in the main text and the practical insight into the equipment given in the appendices, is also available in BG2/2010 (together with more informative illustrations and photographs).

**BSRIA Guide BG2/2010 Commissioning Water Systems**

This is an excellent guide and provides up-to-date information on the commissioning needs of contemporary (circulatory) water distribution systems. Designed to be used in conjunction with CIBSE Commissioning Code W, this joint BSRIA/CIBSE document shares much material (as well as its principal author) with Code W.

One of the key statements at the beginning of the guide is that: ‘Unless commissioning is properly considered during both the design and installation

stages of the project it may not be possible to meet the requirements of CIBSE Code W.’ It then goes on to provide detailed guidance on aspects of design that are essential to enable the systems to be commissioned, noting that: ‘The ease with which the flow rates in a pipework system can be regulated is often dependent on the level of planning that occurs at the design stage.’

Following a comprehensive outline of the information needs for a commissioning specification, the guide goes on to include practical design provisions. These include guidance on design parameters such as acceptable water velocities; overcoming the challenges of setting up systems with low flow rates; and the outline requirements for venting excessive air and deaeration. The guide also includes the suggested tolerances of balance for the various heating and cooling systems – an example is given in Figure 3.

The Guide has particularly useful sections on the application of various commissioning instruments, valves and devices, including clear illustrations and matrices to assist in their appropriate selection, application, location and identification. An example of one of the tables that provides an application summary for different valves is given in Figure 4. There are several examples given of commonly applied commissioning designs that include detailed schematic representations, together with the associated balancing procedures.

**The future for commissioning of water distribution systems**

As new buildings are required to be more sustainable than their predecessors, the need for a rigorous commissioning process has never been greater. The term ‘whole life commissioning’ is sometimes used to emphasise the need for a life-cycle approach to maintaining building systems so that they perform

most effectively. Concepts such as the Soft Landings promote a formalised process stretching some years into the occupation period. The increased adoption of building information modelling looks set to change the whole approach to both maintaining a more coherent picture of the building’s services and driving a more integrated commissioning process.

There are many stories of how systems still do not perform adequately after handover to the client; there is a view that it is only by following some post-occupation commissioning activity that a building is brought into useful operation. In many instances there will be a need

“The term ‘whole life commissioning’ is sometimes used to emphasise the need for a life-cycle approach

to ‘(re-)commission’ some time after the building is in use and has experienced the full impact of seasonal changes. But this need should be properly identified and scheduled.

The lack of appropriate commissioning may surface when highlighted by activity associated with providing a DEC in public buildings, but for many other buildings the lack of proper commissioning might remain undetected for many years, causing unknown consequences to operational efficiencies and the impact on the environment. Hopefully the more stringent planning and reporting requirements under the 2010 Building Regulations will ensure that key parts of the commissioning process do not suffer from inadvertent neglect.

© Tim Dwyer

Valve type	Application notes
Lockshield radiator valves	SUITABLE for radiator, radiant panel, natural convector and underfloor heating circuit connections.
Double regulating valve (DRV)	SUITABLE for system branches, sub-branches and terminal branches where manual balancing of flow rate is required (usually installed as part of a FODRV) USUALLY REQUIRED on three-port control valve by-passes in order to balance the by-pass. (NOT REQUIRED if the circuit flow is held constant by a CFR). NOT USUALLY REQUIRED on the same branches as DPCVs, CFRs, or PICVs, nor on any of the branches feeding to sub-branches containing these devices. NOT REQUIRED on the mainreturn to the pump, unless the pump is a constant feed pump. For variable speed pumps, pump speed should be set using the pump speed controller.

**Figure 4: Partial excerpt of table showing application notes for commissioning devices**  
Source BSRIA Guide BG2/2010

# Module 30

July 2011

**1. In the England and Wales Building Regulations AD Part L, who has to be notified in advance of construction about the commissioning plans?**

- A The client
- B The architect
- C The building owner
- D The building control body
- E The building tenant

**2. Which BSRIA document will assist in documenting the commissioning process?**

- A BG 4/2011
- B BG 6/2009
- C BG 8/2009
- D BG 9/2003
- E BG 10/2011

**3. Which of these CIBSE Commissioning Codes does not relate to a specific area of application/technology?**

- A Code A
- B Code B
- C Code L
- D Code M
- E Code R

**4. Who may be a reasonable choice for taking the responsibility of reviewing the detailed commissioning programme for its impact on the construction process?**

- A Building services contractor
- B Civil engineer
- C Commissioning management organisation
- D Consulting engineer
- E Main contractor

**5. Which of these statements (in the context of this article) is least likely to be true?**

- A The use of a formalised process such as Soft Landings is likely to take account of a period of post occupancy
- B Re-commissioning can help make the building work more effectively across all the seasons
- C Commissioning describes the work undertaken by the Commissioning Engineer
- D It is seen as helpful if a qualified person supplies notifications to the BCB
- E When commissioning heating and cooling water systems, Commissioning Code M, Commissioning Code W and BG2/2010 give complementary information

Name (please print) .....

Job title .....

Organisation .....

Address .....

Postcode .....

Email .....

**Are you a member of:**

CIBSE

If so, please state your membership number

(if available) .....

Other institution

(please state) .....

**To help us develop future CPD modules, please indicate your primary job activity:**

- Building services engineer
- Mechanical engineer
- Electrical engineer
- Commissioning engineer
- Energy manager
- Facilities manager
- Other (please give details) .....

By entering your details above, you agree that CIBSE may contact you from time to time with information about CPD and other training or professional development programmes, and about membership of CIBSE if you are not currently a member.

Please go to [www.cibsejournal.com/cpd](http://www.cibsejournal.com/cpd) to complete this questionnaire online. You will receive notification by email of successful completion, which can then be used to validate your CPD records in accordance with your institution's guidance.

Alternatively, you can fill in this page and post it to:

**N Hurley, CIBSE, 222 Balham High Road, London, SW12 9BS**

## Future features in CIBSE Journal

August 2011	Heat pumps Facades Fire engineering & smoke extraction
September 2011	Air conditioning, air movement & ventilation
October 2011	Industrial & commercial heating Pipework, pumps, valves etc Hotel & leisure facilities supplement*
November 2011	Chilled beams
December 2011	BMS & controls Combined heat & power Lighting Supplement*

\* = Supplements

Editorial submission: Please send editorial proposals/ ideas three months before publication date, eg, 1st October for January publication.

Send to: [editor@cibsejournal.com](mailto:editor@cibsejournal.com).

The final editorial copy deadline is one month before publication date.

### For advertising opportunities contact:

Jim Folley – 020 7324 2786  
or email [jim.folley@redactive.co.uk](mailto:jim.folley@redactive.co.uk)

Mark Palmer – 020 7324 2785  
or email [mark.palmer@redactive.co.uk](mailto:mark.palmer@redactive.co.uk)

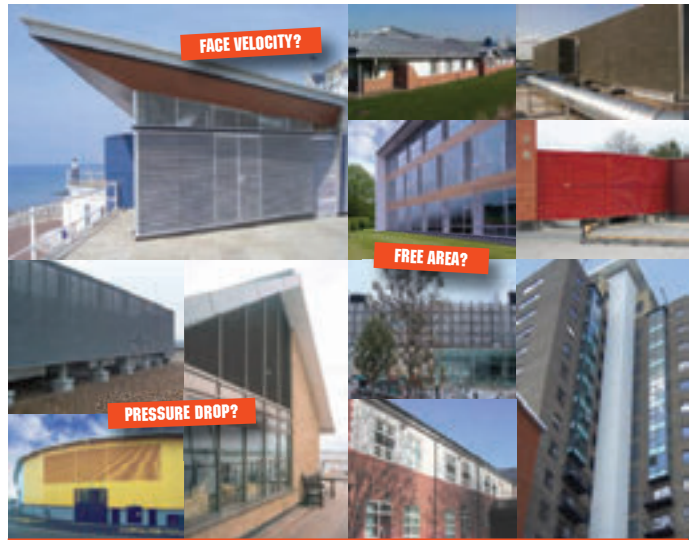

## WE NOT ONLY SOLVE THE PROBLEM, WE ALSO FIT THE SOLUTION.

Sizing louvres accurately is never easy. With so many factors to consider, we thought you might benefit from Naco's experience in this field. One of the leading brand divisions of Ruskin Air Management, our 40 years' experience has seen us expand from glass louvres into standard and high performance metal louvres, sun screens and natural air ventilators.

Along the way we've gathered a lot of expertise. More than enough, for instance, to create a special program to make sizing easier for ourselves and our customers. You can find it on our website.

Simply select an appropriate louvre for your application, then go to 'louvre calculations'. The correct sized louvre can be obtained by entering the air volume and the maximum pressure drop. We're here to help and advise you as to the most suitable products from our vast range to meet your specification.

Don't worry about fitting because that's another thing we can do for you.

There is no easier way. Because there is no-one quite like Naco.

### Ruskin Air Management Limited

For more information, visit [www.naco.co.uk](http://www.naco.co.uk), email [sales@naco.co.uk](mailto:sales@naco.co.uk) or call 01746 761921 now.



Louvres Sunscreens Natural Ventilators

## The CIBSE Technical Symposium

6 & 7 September, 2011 - De Montfort University, Leicester, UK

A unique two-day event giving you the chance to network with experienced practitioners as well as gain insight from research & development professionals in the building services and architectural engineering industries. The symposium will feature over 50 peer reviewed papers drawn from both industry and academia which will be presented in sessions.

### Topics covered include:

- Building Systems Energy and Life Cycle Assessment
- Project Management in Engineering the Built Environment
- Future Design for Sustainable Environments
- Building Engineering Systems Integration and Design
- Renewable and Sustainable Technologies for the Built Environment
- Engineering the Refurbishment and Renewal of Existing Services
- Lighting and Electricity Analysis for a Sustainable Future

### To book a place or for more information:

Visit: [www.cibse.org/events](http://www.cibse.org/events)  
Email: [groups@cibse.org](mailto:groups@cibse.org)  
Telephone: 020 8772 3613





## MHI offers cool solution for new fire station

A new fire station for Cambridgeshire Fire and Rescue Service includes energy efficient cooling and heating, courtesy of Mitsubishi Heavy Industries (MHI). AMP Air Conditioning has supplied a VRF heat recovery system from MHI's KXRE6 range for the £1m construction project. Offering a high degree of climate control, the energy-saving system operates with three inter-connecting pipes to provide heating and cooling to individual indoor units as required, with surplus heat from one area providing useful energy for another.

● For more information call 0207 842 8100 or visit [www.mitsubishiaircon.co.uk](http://www.mitsubishiaircon.co.uk)



## Polypipe units help developer reach Code 3

Polypipe Ventilation, provider of market-leading, energy-saving domestic and light commercial ventilation systems, has had its heat recovery system specified for Larkfleet Homes' extensive new housing development in Bourne, near Peterborough. The first stage of the development, known as 'The Old Laundry', has now been installed, with the HR01 units supplied by Deepings Trading. Larkfleet Homes prides itself on high quality sustainable developments using innovative technology and construction methods. The use of heat recovery in this latest housing development fits well with this philosophy.

● For more information call 08443 71523 or visit [www.polypipe.com/ventilation](http://www.polypipe.com/ventilation)

## BACnet natural ventilation control from TITAN Products now available

The CCM-204-NV provides energy efficient control in buildings by monitoring the natural ventilation on demand and improving the environmental conditions through the control of temperature and CO<sub>2</sub> levels. The CCM-204-NV can control two separate zones and, when used in conjunction with TITAN Products' temperature sensors, CO<sub>2</sub> sensors, rain detectors and window controllers, the CCM-204-NV can create an extremely flexible multi-zone natural ventilation system. This advanced application-specific controller with automatic seasonal adjustment will increase ventilation as CO<sub>2</sub> and temperature levels increase.

● For more information call 0161 406 6480 or visit [www.titanproducts.com](http://www.titanproducts.com)



## Passivent launches new interface to calculate sustainable strategies

A unique software tool to help architects and specifiers accurately and quickly assess the impact of natural daylight on a building's energy performance has been launched by Passivent. The company, Britain's leading supplier of domestic and commercial natural ventilation solutions, has worked closely with leading software house Environmental Design Solutions Ltd (EDSL) to develop the utility – Passivent Sunscop Builder – which complements the already proven Passivent Airscop Builder tool for natural ventilation in buildings. Both tools are based on substantial, recently-published research.

● For more information call 0161 905 5700 or email [projects@passivent.com](mailto:projects@passivent.com)



## Kingspan puts out BREEAM technical advice

Market leader Kingspan Insulation has produced detailed technical bulletins on achieving BREEAM Credits with the use of its Kooltherm and Therma ranges of insulation boards, and the Kingspan TEK Building System, an innovative structural insulated panel (SIP) building system. BREEAM (the Building Research Establishment Environmental Assessment Method) is one of the world's most widely used assessment methods for non-residential buildings. These clear and concise briefings have been published to inform the market about how high quality thermal insulation and SIPs can contribute significantly to achieving credits in BREEAM.

● For more information call 01544 387384 or visit [www.kingspaninsulation.co.uk](http://www.kingspaninsulation.co.uk)

## Durapipe gives hospital pipework a facelift

A host of pipework from Durapipe UK has been specified for the refurbishment of the Royal Berkshire Hospital's maternity department. The renovation of the maternity department, undertaken by specialist mechanical services installer, Airconaire, involved the replacement of the existing water tank and pipework systems that were used to provide both hot and cold water to this area of the hospital. Durapipe SuperFLO and Friatherm pipework systems were specified by leading engineers Buro Happold to cater for all the pipework requirements of the development.

● For more information call 01543 279909 or visit [www.durapipe.co.uk](http://www.durapipe.co.uk)





## Vaillant helps Halton Housing save more than 50% on fuel bills

Vaillant has supplied Halton Housing Trust (HHT) with a solar thermal heating and hot water system and whole-house heating system, as part of a pilot project investigating renewable energy sources and efficient methods of heating sheltered housing. HHT has been working with Sure Maintenance on the installation, which is located in Wavertree Avenue in Widnes. Two Vaillant VFK 145 solar panels were fitted on the roof of the property, along with a 200-litre auroSTOR cylinder, high efficiency ecoTEC plus boiler and an intelligent Vaillant control system.

● For more information call 01634 292300 or visit [www.vaillant.co.uk](http://www.vaillant.co.uk)

## 'Energetic' energy-saving lamps from Senate Electrical

Senate Electrical, one of the UK's leading electrical supplies distributors, has launched a new range of energy-saving lamps under its in-house Sector brand. The Energetic range, which includes CFLi and LED lamps for a wide range of light fittings, boasts energy savings of up to 85% on conventional lamps and a lamp life of 30,000 hours for LED lamps and 10,000 for CFLi lamps. All lamps in the Energetic range are liquid mercury free, with CFLi lamps using Amalgam instead of a safer, more environmentally alternative.

● For more information visit [www.senate.co.uk](http://www.senate.co.uk)



## Hush hush! Sound attenuating vent from Titon

Titon has launched a surface-mounted noise reducing ventilator that is suitable for PVCu, timber and aluminium windows – the SF Sound Attenuator Vent. Compatible with standard 13mm slots, the vent provides excellent sound attenuation for its size and has a very competitive price, making it perfect for both new-builds and retrofitting in domestic or commercial installations. Unlike some competitor 'acoustic' ventilators, the SF Sound Attenuator actually performs to the levels claimed, which is backed up by independent testing.

● For more information visit [www.titon.co.uk](http://www.titon.co.uk)



## New free CableCalc level P – twin and earth calculations

To celebrate 20 years of CableCalc, Castline Systems has released a new, free version of its popular CableCalc program, which will calculate single phase radial and ring circuits wired in twin and earth cable. It even includes free technical support by email. CableCalc level P is a fully working, unlimited use version and provides far more than just simple volt drop calculations. CableCalc level P can be downloaded from [www.castlinesystems.com](http://www.castlinesystems.com) free of charge.

● For more information call 01293 871751 or visit [www.castlinesystems.com](http://www.castlinesystems.com)



## Schools get into their comfort zones with WindowMaster

WindowMaster, Europe's largest provider of natural comfort and smoke ventilation solutions, has installed its innovative indoor climate solution for small and medium-sized buildings in several schools in the south east of England. The Norwood School in London and Hamstel Junior School in Essex are just two of a number of schools that have selected WindowMaster's new NV Comfort control system to provide an optimal indoor climate using natural ventilation.

● For more information visit [www.windowmaster.co.uk](http://www.windowmaster.co.uk)



## Actionair supplies dampers for top scientists

Actionair, part of Ruskin Air Management Ltd, has supplied dampers for the MRC Laboratory of Molecular Biology (LMB), one of the world's most important scientific centres. The birthplace of modern molecular biology, the LMB has undergone a £200m transformation to provide facilities for more than 400 researchers – approximately twice the size of the previous building. Actionair's contribution to this impressive project includes a series of MB120 stainless steel dampers to reduce the casing leakage of the existing ductwork.

● For more information visit [www.ruskinuk.co.uk](http://www.ruskinuk.co.uk)



## Beaver Floorcare make sure Wolverhampton Civic Hall doesn't slip up!

Until recently, the wooden floors at Wolverhampton Civic Hall had been maintained with a regular scrub and dry, and an application of wax, leading to a serious slip hazard. Beaver Floorcare was asked to provide a complete service to create the most slip-resistant floor surface. Following extensive slip-resistance testing, Granwax Barrier Seal was applied to the floor after sanding, before two coats of Granwax Masterfinish and a final coat of Granwax Clearsafe, to ensure a slip-resistant finish.

● For more information call 01773 541177 or email [info@granwax.com](mailto:info@granwax.com)



## Improving the performance of air cooled chillers, dry coolers and condensers and refrigeration plants

EcoMESH is a unique mesh and water spray system that improves performance, reduces energy consumption, eliminates high ambient problems, is virtually maintenance free and can payback in one cooling season. Why should you install EcoMESH?

To reduce running and maintenance costs, for easy retrofit, improved reliability, and increased capacity. Plus, it boasts a self-cleaning filter, a shading benefit, requires no water treatment, and has a longer compressor life.

● For more information call 01733 244224 or visit [www.ecomesh.eu](http://www.ecomesh.eu)



## Rosslyn Chapel begins a new chapter

Rosslyn Chapel is located in Roslin village, seven miles from Edinburgh, and can trace its history back to 1446. After 600 years' service, the building has recently undergone major conservation work to refurbish and upgrade the infrastructure. An important element of this work has been to stabilise the internal temperature. To achieve this, Grundfos Pumps worked with contractors PS Scotland, from Glasgow, to offer a turnkey solution that included a range of Grundfos energy efficient pumps, including ALPHA2 and MAGNA circulators.

● For more information call 01525 850000 or email [uk-sales@grundfos.com](mailto:uk-sales@grundfos.com)



## Kingspan TEK stars in UK's biggest Level 5 development

The Kingspan TEK Building System played a key role in meeting the challenge to construct the country's biggest Code Level 5 development to date. Mayfield Road in Huntingdon is the result of a competition lead by Huntingdonshire District Council, which gave Wherry Housing Association, part of Circle Housing Group, the task of producing 29 homes that meet these exacting standards. Architects PRP came up with an original design to avoid the bland uniform approach that is the simplest route to achieving Level 5 of the Code for Sustainable Homes.

● For more information call 01544 387384 or visit [www.kingspaninsulation.co.uk](http://www.kingspaninsulation.co.uk)



## Birling Consulting offers a unique service – Controllability Reviews

The Carbon Trust – CVT032 Building Controls: it is estimated that up to 90% of heating, ventilation and air conditioning building control systems are inadequate in some way. A common cause is poor controllability due to deficient system design. We can review proposed systems to avoid potential problems, optimise system design and control strategies. We can also advise on integration of modern low carbon solutions, which can require alternative control strategies for optimum energy efficiency.

● For more information visit [www.birlingconsulting.co.uk](http://www.birlingconsulting.co.uk), or call Graham Smith on 01548 830672



## HeatCalc's heat-loss calculations

Castline Systems HeatCalc produces heat loss calculations for the design of heating systems, using the methods described in *CIBSE Guide A3: Thermal Properties of Building Structures*. HeatCalc performs calculations based on continuous heating, with U values supplied for outside walls, windows, floors and ceilings. With support for up to eight-sided rooms, it will design and evaluate energy loss for an entire property or building, with information output into useful graphs and reports.

● For more information call 01293 871751 or visit [www.castlinesystems.com](http://www.castlinesystems.com)

## Marco launch completes steel wire cable tray range

Marco, the UK's largest manufacturer of Steel Wire Cable Tray, and uPVC Cable Management Company, has launched a powder-coated version of its Steel Wire Cable Tray product, completing the company's range. Launched following an upsurge in customer demand, the powder-coated finished product is recommended for exterior and interior use in a range of atmospheric environments, including data centres, and is capable of withstanding a variety of corrosive conditions.

● For more information visit [www.marcoableman.co.uk](http://www.marcoableman.co.uk)



## Remeha Commercial boilers prove winning candidate at London's Heron Tower

Remeha Commercial boilers are helping Heron Tower, of television's *The Apprentice* fame, set the standard for environmental design. The iconic commercial building, with its BREEM rating of 'excellent', has special features including photovoltaic cells, triple skin glazed facades – and four Remeha P520 pressure jet gas high-efficiency boilers. Foreman Roberts specified four cast iron sectional boilers with matching gas fired burners, with a maximum output of 1100kW each, and a control panel capable of operating on future bio-fuel.

● For more information visit [www.remeha.co.uk](http://www.remeha.co.uk), call 0118 978 3434 or email [boilers@remeha.co.uk](mailto:boilers@remeha.co.uk)



## Thermal energy storage

Phase Change Materials (PCM) store and release thermal energy during the process of melting and freezing, and the latest range of PCM solutions between -100C and +885 C offer new application opportunities. For example, the excess capacity of existing +7C water chillers can be stored in +10°C PCM containers overnight, using lower ambient and lower electricity costs. This efficient and lower-cost stored energy tops up the day peak loads, saving considerable running costs, doubling the existing system capacity, or halving the chiller capacity for new design.

● For more information call 01733 245511 or visit [www.cmproducts.net](http://www.cmproducts.net)

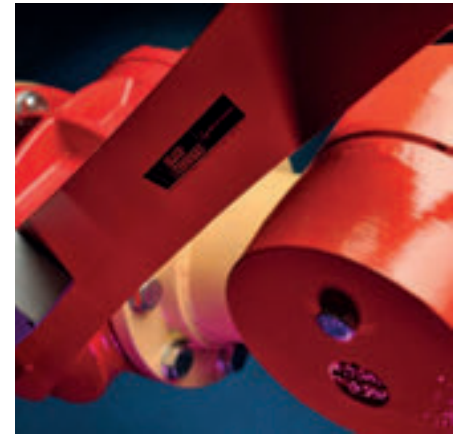
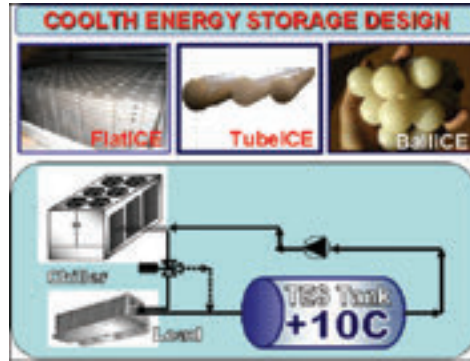

## Black Teknigas enhances gas safety with free fall fire valve

Leading UK gas control equipment manufacturer, Black Teknigas, has introduced a new system of free fall fire valve equipment suitable for oil and gas installations. This range of valves and accessories provides a complete, positive 100% fuel isolation system that will automatically operate in the event of excessive temperatures or alarm signal. Black Teknigas is a division of Watts Industries, one of the world's foremost manufacturers of valves and controls.

● For more information call 01480 407074 or visit [www.blackteknigas.com](http://www.blackteknigas.com)

## CPD examines benefits and sustainability of fan convector heating

Smith's Environmental Products' new CPD presentation, 'Fan Convector Heating', explains principles of forced convection heaters and the many benefits they provide as an alternative to traditional radiator and boiler systems. Available for presentation in person and online at [www.academy-elearning.co.uk](http://www.academy-elearning.co.uk), it compares system efficiency and energy savings and examines what can be achieved with low temperature systems using ground- or air-source heat pumps. Specific reference is made to SAP calculation, Building Regulations and practical implications affecting designers and facilities managers. The presentation is approved by the Construction CPD Certification Service.

● For more information call 01245 324900 or email [jimbennett@smiths-env.com](mailto:jimbennett@smiths-env.com)



## Even higher efficiency from Purmo Compact's Type 33

Purmo, the radiator manufacturer at the forefront of the use of radiators for low temperature heating systems, provides a Type 33 version of its popular Compact radiator for the UK market, especially for those wishing to make use of renewable energy sources and technologies. The Compact is tried and tested as an easily controllable and highly responsive heat emitter. The Compact Type 33 is an excellent choice for heating systems operating at lower temperatures.

● For more information call [www.purmo.co.uk](http://www.purmo.co.uk)



## New from MHS Boilers: Thision L

MHS Boilers, part of ELCO Heating Solutions, has launched THISION L, a new range of light commercial gas fired, high efficiency, wall hung condensing boilers with outputs from 45kW to 145kW. Featuring a double helix stainless steel heat exchanger, the boilers have a high turndown rate of 6:1, affording the potential for accurate output-to-load matching. Up to eight boilers can be installed in a purpose-built cascade rig, delivering an industry leading combined output of up to 1,140kW.

● For more information visit [www.mhsboilers.com](http://www.mhsboilers.com)

## Andrews Solarflo system in City refurbishment

Andrews Water Heaters, part of Baxi Commercial Division, supplied the SOLARflo water heating system and MAXXflo gas-fired storage water heater installed at 23-25 Great Sutton Street, which won five awards, including the Sustainable Buildings Award for architects John Thompson & Partners, at the City of London Corporation's Sustainable City Awards. The award recognised the exemplary upgrading of an existing 1920s warehouse to incorporate systems, technologies and materials that substantially reduce energy demand and emissions, provide sustainable energy supply and minimise both water usage and waste.

● For more information call 0845 070 1055 or visit [www.andrewswaterheaters.co.uk](http://www.andrewswaterheaters.co.uk)

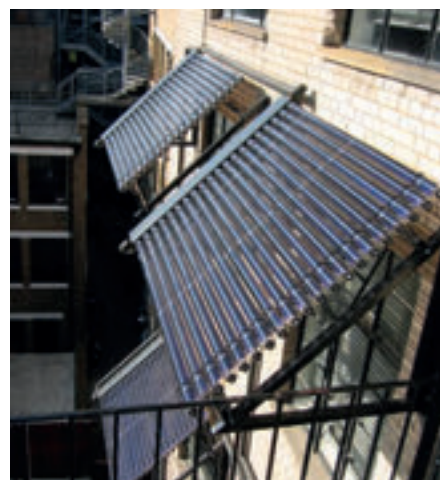

## Double the incentive

Currently, straight wood burning stoves are not covered under the Renewable Heat Incentive (RHI), despite reaching efficiencies of more than 90%. However, Rika's Evo Aqua combines water heating capabilities, making it eligible for the cash-back scheme. With the domestic arm of the RHI set to be introduced later in the year, your customers could be getting money from the government and free fuel courtesy of Euroheat. Rika's stove-only range represents the cutting edge of wood pellet burner design, with contemporary styles to suit any home.

● For more information visit [www.euroheat.co.uk/rikaoffer](http://www.euroheat.co.uk/rikaoffer)



## Senate Electrical launches buyer's guide

Leading electrical supplies distributor, Senate Electrical, has launched a 168-page Buyer's Guide, designed to provide customers with details of its extensive product ranges and pricing. The guide features a fresh modern design, clear product images and a brief key product description. Using colour coding to clearly identify the different sections, which include wiring, cable, lighting, test and inspection, data networking and switchgear and circuit protection, the guide is very easy to use.

● For more information visit [www.senate.co.uk](http://www.senate.co.uk)



## KNX Consultants offer independent consultancy services

KNX UK Association member KNX Consultants now provides a range of independent consultancy and training services. As a KNX Partner and a certified KNX tutor, owner Ben Lewis can offer support to systems integrators undertaking initial KNX installations and needing an experienced eye and depth of knowledge. KNX Consultants can also provide one day introductory KNX training courses on site using portable training rigs. This is an ideal way for systems integrators and end users to get a quick introduction to KNX.

● For more information call 0845 869 5908 or visit [www.knx.org](http://www.knx.org)

## Prysmian FP approved by London Underground

Prysmian's FP200 Gold, FP600S and FP400 are all approved for use in the London Underground, perhaps the most onerous environment for any cable product. This means that engineers and contractors can specify and install FP200 Gold, FP400 and FP600S with confidence throughout the London Underground network and stations, above and below ground. Prysmian's FP cables boast the ultimate performance under extreme conditions, and represent the ideal choice when the highest quality, fire performance cabling is required.

● For more information call 023 8029 5029 or email [cables.marketing.uk@prysmian.com](mailto:cables.marketing.uk@prysmian.com)



## Best thermal imaging camera from Flir

The new FLIR T600bx series cameras are unique. These best-in-class models, with a wide choice of lenses, are easy and quick to use, designed for flexible application and provide 640 x 480 pixel thermal images on which you can see the smallest detail. A rotating optical block makes it easy to capture images from any angle comfortably, and these cameras introduce a rich list of leading edge features. Thanks to FLIR's latest wireless technology, you can send images to a PC, iPhone or iPad.

● For more information visit [www.flir.com/thg](http://www.flir.com/thg)



## Electric Boilers and Water Heaters from Atlantic

Atlantic Boilers is a supplier of condensing and highly efficient boiler-plant. Its range of electric boilers include GWR, a wall-hung electric boiler complete with integral pump, expansion vessel and controls that help ensure low fuel bills for modern buildings. It is compact and requires no flues, and installation is simple and low cost. Compacte, a floor-standing, electric boiler that is economic to install and run, benefits from low-cost running with BREEAM buildings and has a maximum working pressure of four bars. Multi-Elec is a floor-standing electric boiler with an output of up to 630kW. It has a small footprint, and comes as a complete package with a control panel. Multi-Elec is offered in 17 models to suit different output and installation needs.

● For more information email [nabeela@atlanticboilers.com](mailto:nabeela@atlanticboilers.com) or visit [www.atlanticboilers.com](http://www.atlanticboilers.com)



# PRODUCTS & SERVICES

Telephone: 020 7880 6206 Email: darren.hale@redactive.co.uk

## Classroom ventilation units

Aircraft Air Handling's 260mm-high classroom ventilation units are silenced to nr25. The plate recuperator is 60% efficient, with an air volume 0-500 litres. Heating: LPHW/ELECTRIC. Cooling: CW/DX. Larger air volumes and bespoke units are available.

● For more information visit [www.aircraftairhandling.com](http://www.aircraftairhandling.com)



## DRU Style heaters keeping Mojo warm in Twickenham

Verve Properties is a property development company specialising in restoring and converting former brownfield sites and derelict buildings throughout London. One recent development is Crane Mews, a collection of former industrial buildings totalling 17,000 square feet next to the River Crane in the affluent suburb of Twickenham. Verve has selected DRU Style balanced flue gas wall heaters to heat the buildings. They provide an attractive and efficient alternative to radiators and only consume gas when required. They can also be turned off when the property is not in use.

● For more information call 0161 793 8700 or visit [www.drufire.co.uk](http://www.drufire.co.uk)



## Matrix radiators feature at Leicester venue

A new conference, banqueting, office and resource centre in the heart of Leicester City Centre is being kept warm and comfortable thanks to 70 Matrix Horizontal steel panel radiators from MHS. Located next to the city's historic Cathedral and officially opened by The Bishop of Leicester, St Martins House is a former grammar school building that has been converted into a multi-use events and services venue. The £7m centre has been nominated for a Leicester Civic Award.

● For more information call 01268 546700 or visit [www.mhsradiators.com](http://www.mhsradiators.com)

# DIRECTORY Your guide to building services suppliers

Telephone: 020 7880 6206 Email: [cibsedirectory@redactive.co.uk](mailto:cibsedirectory@redactive.co.uk)

## Air Conditioning



**For total solutions in air-conditioning**

E: [info@clivet-uk.co.uk](mailto:info@clivet-uk.co.uk)  
 W: [www.clivet.com](http://www.clivet.com)  
 T: 01489 572238  
 W: [www.versatemp.co.uk](http://www.versatemp.co.uk)

## Air Handling



Manufacturer of high quality bespoke AHU's and fan coils.

Specialists in refurbishment and site assembly projects.

Expedient delivery service available.

Aircraft Air Handling Ltd  
 Unit 20, Moorfield Ind Est,  
 Cotes Heath, Stafford, ST21 6QY  
 Tel: 01782 791545 Fax: 01782 791283  
 Email: [info@aircraftairhandling.com](mailto:info@aircraftairhandling.com)  
 Web: [www.aircraftairhandling.com](http://www.aircraftairhandling.com)

## CAD Services



- Building Services Work Undertaken
- 2D Draughting
- 3D Autocad MEP
- Record Drawings
- Excellent Rates & Turnaround Service
- MEP BIM Services

Contact Stephen:-  
 T: 020 7043 7491  
 F: 020 7043 7493  
 E: [cad@cadeuro.co.uk](mailto:cad@cadeuro.co.uk)  
 W: [www.cadeuro.co.uk](http://www.cadeuro.co.uk)

## LST Radiators



**Range of models to suit all budgets and applications**

- Easy installation – ready assembled
- BSRIA tested outputs and surface temperatures
- SteriTouch® antimicrobial surfaces as standard
- Energy efficient copper aluminium emitters
- Attractive yet functional design

Call 01787 274135 [www.autron.co.uk](http://www.autron.co.uk)





## Energy Efficiency



**Ground Source Heat Pump Installations**

Meeting Renewables Targets

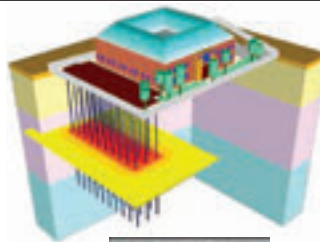

Tel: 02392 450889  
 Fax: 02392 471319  
[www.groenholland.co.uk](http://www.groenholland.co.uk)



Certificate Number MCS 1201 Heat Pumps

## Pump Packages



Leaders in fluid pumping equipment and controls

- Water Pressure Booster Sets
- Sealed System Pressurisation Units
- Tank Level & Temperature Controls
- Energy Efficient
- Bespoke Design Service

To discuss your project please contact Jim Rusbridge

Head Office: 01206 215121  
 email: [info@aquatechpressmain.co.uk](mailto:info@aquatechpressmain.co.uk)  
[www.aquatechpressmain.co.uk](http://www.aquatechpressmain.co.uk)

## Refurbishment



Energy Efficient Refurbishment solutions for increasing the performance and reliability of existing Air Handling Units of any manufacture.

- Replacement, Refurb or Retrofit
- Site Survey, Design, Manufacture
- Basic to High Spec Installations
- In-depth Technical Support from survey to final commissioning

For more information, call Steve Peck on 01206 505909 or e-mail [tech@imofa.co.uk](mailto:tech@imofa.co.uk)

[www.imofa.co.uk](http://www.imofa.co.uk)  
 AHU Designers & Manufacturers



## Snr. Electrical Engineer

£36-40k, West Midlands

A well respected consultancy established since 1978 and employing over 30 engineers is currently recruiting. The company are in need of a candidate who has the drive and determination to match the realistic career progression opportunities within the company. Successful candidates will have been responsible for initial and detailed design of electrical services using Hevacomp or Amtech software and will have previously led projects and design teams, along with possessing strong client interaction skills.  
BAR645/JA

## Principal Electrical Engineer

£40-50k, Surrey

Our award-winning client offers a fantastic career progression opportunity for a tenacious and motivated engineer. The ideal candidate will have been responsible for leading design teams on a range of projects, managing a revenue stream of over £25k per month, completing tender packages, preparation of budget cost reports, along with attending design and client meetings. The ideal candidate will also have completed a relevant engineering degree and be a chartered engineer.  
BAR634/JA

## Electrical Associate

To £55k +benefits, London EC1

Our client is one of the largest international consultancy groups in the world, a global business providing management and consultancy services to the built and natural environment. They seek a new associate-level electrical engineer to provide additional technical capability and management to the M&E team. The business unit in question undertakes projects in London & Internationally and operates in a variety of sectors including education, healthcare, industry, historic buildings, data centres, high-rise, retail, commercial and financial. The successful applicant is likely to be an existing associate, or an outstanding principal engineer.  
BAR654/PA

## Senior M&E Engineers

Circa £50k, Winchester

Our client is involved in innovative Building Services solutions and is the preferred choice with clients seeking low energy designs within the hotel, commercial, retail and banking sectors. All applicants should possess the ability to demonstrate a strong interest, and experience, in the execution of sustainable solutions, and will be responsible and accountable for the overall design, technical delivery, quality and management of projects within defined budget and timescales. Preferred applicants will be degree qualified.  
BAR545/PA

For further information and to apply, please call us on **0845 519 4455** or email [cv@b-a-r.com](mailto:cv@b-a-r.com)

Discover your future at [www.b-a-r.com](http://www.b-a-r.com)

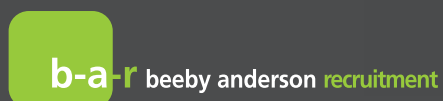

Thinking of your future

## GOVERNMENT OF BERMUDA

### MINISTRY OF PUBLIC WORKS

#### Principal Electrical Engineer

PS 36-38 \$113,480-\$122,064 (US\$ equivalent)

Department of Works and Engineering

Ref: 5445/82/0075/RA/OS

The Department of Works and Engineering within the Ministry of Public Works is inviting applications for the post of Principal Electrical Engineer.

Under the general direction of the Chief Engineer and the functional direction of the Assistant Chief Engineer/Operations, the post holder will be responsible for managing the Electrical Engineering Section within the multi-disciplinary Works and Engineering Department. The Electrical Engineering Section is responsible for the design and maintenance of all electrical and mechanical installations associated with Government buildings and industrial infrastructure, including electrical distribution, lighting systems, fire protection, security and telecommunications systems, HVAC and building energy management systems. The Electrical Engineering Section is also responsible for the design and installation of new street lighting and the administration of the Street Lighting Act.

Applicants must possess a recognized Bachelor's Degree in Electrical Engineering, or equivalent and must be a corporate member of the Bermuda Association of Professional Engineers or an equivalent professional engineering body overseas. Applicants must also have five (5) years' post professional qualification experience, and must be fully conversant with current computer languages. Applicants must also have a proven electrical power systems background or other recognized specialty including the design of medium and low voltage distribution systems, motor circuits and controls and system protection. In addition, applicants must be fully conversant in the design of lighting, fire protection, security and telecommunication systems.

Applicants should have a sound knowledge of the US National Electrical / NFPA codes or equivalent. Additionally applicants should be conversant with preparing and working within budgets.

The successful candidate will be responsible for leading and supervising professional engineers and technologists. Applicants interested in being considered for the above post **MUST** complete a **security vetting form (to include passport and social insurance numbers)**.

This position will be offered on a three (3) year contract term. Any persons wishing to be considered for the position advertised may apply by submitting a completed Government of Bermuda application form (which can be downloaded from [www.gov.bm](http://www.gov.bm)) quoting the appropriate reference number, to:

**the Secretary of the Public Service Commission, 3rd Floor, Ingham and Wilkinson Building, 129 Front Street, Hamilton HM12, BERMUDA; email: [hr@gov.bm](mailto:hr@gov.bm) or by fax: 441-295-2858.**

**Closing date: August 5, 2011.**



We are seeking experienced personnel for both immediate & future posts in Abu Dhabi, Dubai, Oman, Saudi & Qatar.

We are looking for –

- Commissioning Managers (Mechanical, Electrical & ELV)
- Building Fabric & Service Technical Authors
- Document Managers

Salaries from £40k – £60K (Tax Free) plus Housing, flight & car allowances and other benefits.

Please contact Kevin Day  
kevin.day@cmlgroup.ae

BURJ KHALIFA

BAHRAIN WORLD TRADE CENTER



ST REGIS RESORT – SADIYAT ISLAND



PULLMAN HOTEL

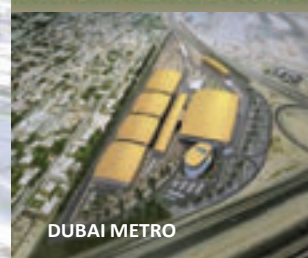

DUBAI METRO



AL ZEINA “ AL RAHA



Specialists in Building Services Recruitment

**Senior Electrical Engineer | London | to £45K + | ref: 7428**

We are looking for an engineer to join this busy practice. You will ideally be Chartered with experience of Rail biased projects. This is an opportunity to join a leading company with great career prospects!

**Chief Mechanical Engineer | UK Wide | to £NEG! | ref: 8118**

We are currently looking for a highly technical mechanical engineer to lead and develop the technical support team. You will be required to represent the company on all technical related matters including evaluating new systems and processes that would be beneficial to the business. Please call for further information!

**Senior Mechanical Engineer | Hampshire | to £40K + | ref: 4512**

Our client is a growing practice with a solid order book. They are looking for a proactive, forward thinking and experienced mechanical engineer to join the team. Great career opportunity.

**Intermediate Electrical Design Engineers | London | £NEG! | ref: 1293**

We are ideally looking for degree qualified engineers who are looking for the chance to progress and gain invaluable experience at an award winning practice.

**Electrical Engineer | Hampshire | to £45K+ | ref: 2050**

We are looking for an experienced engineer to join our blue chip client. You will have a proven track record in design and have the ability to mentor junior engineers. Good career opportunity.

**Cad Technician | Hampshire | to £35K | ref: 4686**

We have a requirement for an experienced M&E cad technician you will be proficient in 2D with experience or an interest in 3D. Revit training will be provided. Rare opportunity.

For more information or a confidential discussion please contact Mark Butter

**t: 02392 603030**

e: mark.butter@blueprintrecruit.com www.blueprintrecruit.com  
E3 & E5 Heritage Business Park, Heritage Way, Gosport, Hampshire PO12 4BG

## Senior Engineering Manager/Director

Johnson Controls has an exciting opportunity for an Engineering Director to join its team based in central London. The successful candidate will lead an in-house team that delivers engineering services and critical engineering operations to a high profile client.

The ideal candidate will have;

- Experience of managing critical engineering operations for a blue chip client across multiple sites
- Engineering degree or equivalent and ideally be a chartered engineer
- Proven ability to lead and inspire a team
- Excellent client liaison skills and the drive and determination to forge long term strategic relationships

Please send all applications to [ukcareers@jci.com](mailto:ukcareers@jci.com) quoting the reference number **055136** or visit our careers website for further details.



[www.johnsoncontrols.co.uk/careers](http://www.johnsoncontrols.co.uk/careers)





PICK EVERARD

**Building Services Engineers  
Leicester & Nottingham**

Pick Everard is a leading, independent and multidisciplinary engineering and architectural partnership with eight offices in the UK and our head office based in Leicester.

Due to an increasing workload we are currently seeking Intermediate and Senior level Mechanical Building Services Engineers with sound technical and design ability to join us to deliver the highest quality client focused service.

For further information about these roles, the projects we are working on and details of how to apply please visit our website: [www.pickeverard.co.uk](http://www.pickeverard.co.uk).

The closing date for applications is: 22nd July 2011

[www.pickeverard.co.uk](http://www.pickeverard.co.uk)

We are an equal opportunities employer.

No agencies please.



Visit [www.bsvconsultants.co.uk](http://www.bsvconsultants.co.uk) to find out about us and Building Services vacancies.

- Mechanical Design Engineer** - Intermediate Ref:11995  
Central London, from £27-37k
- Electrical Design Engineer** - Intermediate Ref:12034  
North London, from £27-35k
- Electrical Design Engineer** - Intermediate Ref: 12034  
Oxford, from £25-35k
- Electrical Design Engineer** – Team Leader Ref: 11730  
Oxford, from £50-55k
- Mechanical Design Engineer** – Senior Ref: 10872  
Reading from £40-45k
- Project Manager - Construction M&E - D&B** – Ref 12122  
Midlands from £28-30/hr
- Electrical Design Engineer** – Senior Ref: 10230  
Manchester from £40-47k
- Mechanical Design Engineer** – Senior Ref: 10872  
Manchester from £40-47k
- Building Services Engineer** – Property Ref: 11688  
City of London from £35-47k
- Energy Assessor Consultant Engineer** – Ref: 10921  
London, W1 from £30-45k
- Electrical Design Engineer - Inter/Senior** – Ref:12034  
Bristol, from £28-40k
- Mechanical Design Engineer - Inter/Senior** – Ref 12034  
Bristol, from £28-40k
- Mechanical Contract Engineer - Trainee** – Ref 12113  
Essex from £25k
- Electrical Project Engineer - Rail** – Ref 12059  
Manchester from £50-60k

Reference the vacancies on our website or call  
Darren Warmington for full details about these jobs.  
tel. 01483 768600  
email: [darrenw@bsvconsultants.co.uk](mailto:darrenw@bsvconsultants.co.uk)  
[www.bsvconsultants.co.uk](http://www.bsvconsultants.co.uk)

**Diamond Light Source is the UK's national synchrotron science facility. Located at Harwell Science and Innovation Campus in Oxfordshire, we enable world-leading research across a wide range of scientific disciplines and industrial applications.**

**Assistant Beamline Design Co-ordinator** Ref: DIA0624/SB

**Circa £33k (dependent upon skills, qualifications and experience)  
Permanent**

To assist the BDC (Building Design Co-ordinator) in delivering designs, specifications and tendered work packages resulting in the selection of contractors to carry out building and building services projects.

**We are committed to equality of opportunities for all and offer a competitive salary (dependent upon skills, qualifications and experience), comprehensive benefits, an index-linked pension scheme and flexible working hours.**

For an application form and further information including work permit and visa requirements for non-EU nationals please visit our website at [www.diamond.ac.uk](http://www.diamond.ac.uk) , telephone our recruitment line on 01235 778218 or write to us at the address below, quoting the appropriate reference number.

Closing date: 15th July 2011.

[www.diamond.ac.uk](http://www.diamond.ac.uk)  **diamond**

Diamond Light Source Ltd, Diamond House,  
Harwell Science and Innovations Campus, Didcot, Oxfordshire OX11 0DE

To advertise your jobs with *CIBSE Journal* contact:  
**020 7880 6243 | [cibsejobs@redactive.co.uk](mailto:cibsejobs@redactive.co.uk)**

**CIBSE JOURNAL**

**JOBS**

**New jobs site with latest vacancies now live**

Visit [jobs.cibsejournal.com](http://jobs.cibsejournal.com) to find your next career move

## Certification Technical Manager

Up to £40,000



CIBSE would like to appoint a Certification Technical Manager to play a major role in helping CIBSE Certification identify and respond to emerging market opportunities. This post requires a highly motivated individual with the drive to succeed and take CIBSE Certification to the next level of operation.

A qualified Energy Assessor with a minimum of 2 years experience, you must have indepth technical knowledge of building services and the requirements of EPBD. You will be responsible for the day to day management of activities in the team, ensuring all communications are effective and accurate; offer technical support to energy assessors and certification staff; contribute to the audit process; and seek and deliver business growth development.

For further details please visit [jobs.cibsejournal.com](http://jobs.cibsejournal.com), or call 0208 772 3682 or email [humanresources@cibse.org](mailto:humanresources@cibse.org)

To apply for this role, please send your CV, and cover letter, to [humanresources@cibse.org](mailto:humanresources@cibse.org) marked for the attention of Lammy Oluborode. For any queries or for further information call 020 8772 3682.

**Closing date: 13 July**



## Fulfil your potential...

### CIBSE Mid Career College

- Respected, high quality training for building services professionals
- Courses cover a wide variety of technical topics
- Keep your CPD hours up to date whilst enhancing your skills
- In-house training provides flexible, cost effective learning tailored to your needs.



For more information contact our events team on 020 8772 3660, email [eventbookings@cibse.org](mailto:eventbookings@cibse.org) or visit

[www.cibsetraining.co.uk/mcc](http://www.cibsetraining.co.uk/mcc)



Mecserve Ltd is a well respected leading Building Engineering Consultancy based in Wallington, Surrey. Mecserve provide cutting edge consultancy services to a broad range of blue chip clients.

We are currently looking for candidates with the potential and ambition to become key members of our management team over the next three to five years.

We are currently looking to fill the following positions:

### Associate/Associate Director (Mechanical)

You should:

- be a degree qualified engineer with significant relevant experience
- be chartered or be able to demonstrate the equivalent experience
- have an excellent knowledge of the construction industry
- have an excellent technical knowledge of mechanical building services

In addition to these technical skills you should:

- have experience of providing client facing services
- have experience of managing projects
- help to develop the business in the future

The salary offered will depend on the skills and experience the candidate brings to the role. Benefits include childcare voucher scheme, private healthcare and a performance related bonus scheme.

If you are interested in either role please send a current CV and covering letter to: [recruit@mecserve.com](mailto:recruit@mecserve.com)

**Website: [www.mecserve.com](http://www.mecserve.com)**



### [www.conwy.gov.uk](http://www.conwy.gov.uk)

Bordered to the north by a magnificent coastline and encompassing a huge section of Snowdonia National Park, it's safe to say that Conwy is a truly beautiful part of the country.

At Conwy County Borough Council the huge range of careers we offer is matched by an equally extensive list of employee benefits.

If you're interested in working for one of the region's largest employer visit: [www.conwy.gov.uk/jobs](http://www.conwy.gov.uk/jobs) and apply by email to [jobs@conwy.gov.uk](mailto:jobs@conwy.gov.uk) or call 01492 576124.

#### Property Management and Asset Services, Conwy, North Wales

#### Building Services Design Engineer - Mechanical (Ref: 732)

Current grade and salary for this post is Grade G08: £30,011 - £32,800 pa

The role focuses on the provision of a mechanical design service for capital and maintenance projects.

You will need to be a Chartered Engineer, or be working towards chartered status with minimum HNC Mechanical Engineering (Building Services) or equivalent, be fluent in CAD applications and the use of proprietary design software. You will have effective presentation and communication skills with the ability to manage and deliver projects to programme and to budget and also have experience of a multidisciplinary property support service environment.

The ability to communicate through the medium of Welsh is desirable.

For further information please contact Adrian Ives, Property Maintenance and Facilities Manager on 01492 574260.

**APPLICATION FORMS TO BE RETURNED BY MIDDAY 25/07/2011.**

All posts are subject to Job Evaluation. If not informed within 3 weeks of the closing date, candidates must assume they have not been shortlisted for interview and will therefore not be notified in writing.

In promoting equal opportunities Conwy welcomes applicants from all sections of the community. All disabled applicants who meet the essential job requirements will be guaranteed an interview.

- Competitive Salary and Benefits Package
- Generous Leave Entitlement
- Final Salary Pension Scheme
- Excellent Training/Development Opportunities



# Events & Training

**NATIONAL EVENTS AND CONFERENCES**

**Realising our potential to adapt to climate change**

**06 July, Swansea**  
This seminar looks at the holistic, integrated approaches and policies needed to produce healthy built environments designed to meet energy and resource use targets, adapt to climate change and provide for nature, using ecosystem services as a lens  
[www.architecture.com](http://www.architecture.com)

**Summertime overheating in buildings and the urban environment**

**21 July, Balham, London**  
Overheating of the built environment is already a serious problem, which will further intensify in the future. This one-day conference event will focus on policy drivers, assessing overheating, new UKCP09 data and urban heat islands, and include case studies from winners of the Design for Future Climates: adapting buildings 2010 competition  
[www.cibsetraining.co.uk](http://www.cibsetraining.co.uk)

**CIBSE Technical Symposium**  
**06-07 September, Leicester**

Two-day event showcasing research and technical developments. The symposium will include papers that are relevant for the full range of technical areas of interest to CIBSE members  
[www.cibse.org/events](http://www.cibse.org/events)

**Energy Event**  
**13-14 September, NEC Birmingham**

Leading business exhibition and conference, focusing on energy procurement, management and efficiency. Free to attend  
[www.theenergyevent.com](http://www.theenergyevent.com)

**HBF Planning Conference**  
**22 September, Milton Keynes**

What will the draft National Planning Policy

mean for your existing plans and land holdings? Your current land options and planning strategies? Early booking discount applies until 15 July.  
[www.house-builder.co.uk](http://www.house-builder.co.uk)

**Energy Solutions 2011**  
**11-12 October, London**

Energy Solutions, an energy management and procurement event, will bring together energy management and procurement professionals from across the UK.  
[www.energysolutionsexpo.co.uk](http://www.energysolutionsexpo.co.uk)

**Professional Lighting Design Convention 2011**  
**19-22 October**

**Madrid, Spain**  
PLDC is a three-day conference offering around 65 papers from internationally renowned speakers and young professionals. The conference is accompanied by a manufacturers' exhibition, offering industry partners a platform to present their companies to delegates and broaden their business contacts.  
[www.pld-c.com](http://www.pld-c.com)

**SOCIETY OF LIGHT AND LIGHTING**

**LEDs – a CRI for help**  
**11 October 2011**

Details to be confirmed  
[www.sil.org.uk](http://www.sil.org.uk)

**CIBSE GROUPS AND REGIONS**

**Intelligent Buildings Group seminar: designing for intelligent underground building**

**06 July, London**  
Seminar looking at designing underground buildings  
[www.cibse.org/events](http://www.cibse.org/events)

**Biomass Sizing Tool**  
**19 July, London**

CIBSE Home Counties South East region offers CIBSE members free attendance to this Carbon Trust event that looks at a biomass design support tool  
[www.cibse.org/events](http://www.cibse.org/events)



Greg Davies head of service development at Elementus, will be chairing the conference

**Thermostatic Control Technology**

**20 July, Manchester**  
A Society of Public Health Engineers' technical meeting  
[www.cibse.org/sophe](http://www.cibse.org/sophe)

**Pinholing in Copper Domestic Water Systems**  
**15 September, Bristol**

A Society of Public Health Engineers event  
[www.cibse.org/events](http://www.cibse.org/events)

**Society of Façade Engineering technical meeting**

**21 September, London**  
Film on glass, and film in glass  
[www.cibse.org/sfe](http://www.cibse.org/sfe)

**Under Floor Heating**  
**21 September, Manchester**

Society of Public Health Engineers event  
[www.cibse.org/events](http://www.cibse.org/events)

**Symposium on lift and escalator technologies**  
**29 September 2011, Northampton**

[www.cibseliftsgroup.org/events](http://www.cibseliftsgroup.org/events)

**CPD TRAINING**

Visit [www.cibsetraining.co.uk](http://www.cibsetraining.co.uk), call 020 8772 3660 or email [eventbookings@cibse.org](mailto:eventbookings@cibse.org)

**ELECTRICAL SERVICES**

**Electrical Services Explained (three days)**  
**27-29 September 2011, Birmingham**

**ENERGY EFFICIENCY AND SUSTAINABILITY**

**Part L Building Regulations**  
**07 July 2011, Birmingham**

**Carbon Reduction Commitment**  
**12 July 2011, London**

**Part L Building Regulations**  
**13 September 2011, Manchester**

**Building Regulations Section 6 (Energy)**  
**23 September 2011, Aberdeen**

**Part L Building Regulations**  
**29 September 2011, London**

**Legionella under the microscope**

Despite new technology adding more sophisticated systems and services to our buildings for sustainability and business objectives, outbreaks of legionella are still occurring.

This one-day conference will look at best practice in 2011, and how industry must comply. It will also explore what we should be doing to keep pace of changes in the industry, while maintaining the integrity of our legionella management.

Experts in the field of legionella research and management will be speaking on the day, taking attendees through the technical, legislative and industry issues you should be aware of. For more information and to register for the conference, visit [www.cibsetraining.co.uk](http://www.cibsetraining.co.uk)

**FACILITIES MANAGEMENT**

**Preparing FM and maintenance contract**  
**28 September 2011, London**

**MECHANICAL SERVICES**

**Mechanical Services Explained**  
**04 - 06 July, Loughborough**

**Mechanical Services Explained**  
**21-23 September, Belfast**

**Design of ductwork systems**  
**20 September 2011, London**

**PUBLIC HEALTH AND WATER**

**Sanitary and rainwater design using BS EN 12056:2000**  
**15 September 2011, London**

Send your event details to [cbailey@cibsejournal.com](mailto:cbailey@cibsejournal.com)

# High-Performance Green Buildings

Find out  
What's new in  
**Hevacomp**

design  
components  
design  
sustainability  
architecture  
sustainability  
architecture  
geometry



Image courtesy Hamilton Associates



Image courtesy HKR Architects



Image courtesy Foster+Partners

## Software for Building Energy Design, Analysis and Simulation

Successfully creating high-performance buildings demands the accurate prediction of energy consumption, CO<sub>2</sub> emissions, operating costs, and occupant comfort.

Bentley's comprehensive suite of industry-leading energy design, simulation and analysis applications, including **Bentley Hevacomp** and **Bentley Tas**, provides today's professionals with these capabilities and more, facilitating the productive delivery of sustainable 'green' buildings.

These applications are used by leading firms worldwide to effectively simulate and analyze building energy performance – optimizing the balance of function, comfort, and energy and carbon impact and helping building teams sustain our environment.

[www.bentley.com/CIBSE](http://www.bentley.com/CIBSE)

**Already a Hevacomp user?  
Improve your productivity  
with Training:**

[www.bentley.com/UK-Green-Training](http://www.bentley.com/UK-Green-Training)



For more information:

**0808 101 9247 (UK only)  
+353 1 436 4600 (Europe)**

Press 1 for energy modelling and building services software

**1-800-BENTLEY (US)**

© 2011 Bentley Systems, Incorporated. Bentley, and the "B" Bentley logo are either registered or unregistered trademarks or service marks of Bentley Systems, Incorporated or one of its direct or indirect wholly owned subsidiaries. Tas copyright EDL. Used with Permission. Other brands and product names are trademarks of their respective owners.

 **Bentley**  
Sustaining Infrastructure



# CMR

## in complete control

CMR Controls manufactures low air pressure and air volume measurement sensors and control systems for standard air conditioning, clean rooms, sterile laboratories, containment facilities, and fume cupboard extract systems.



### DPM PRESSURE SENSOR

Panel Mount Pressure or Velocity Transducers with remote alarms, analogue and digital interfaces. Traceable calibration certificates supplied as standard.

### AIR MANAGEMENT SYSTEM

A complete turn-key system to control room pressure to +/-1Pa. Fume cupboard face velocity to 0.5m/s at high speed and provide constant air changes into the labo - clean room.

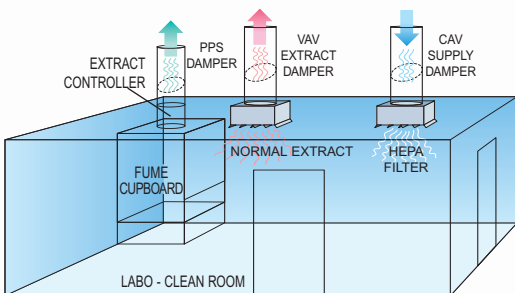

### PRECISION COMPONENTS FOR VENTILATION AND PROCESS CONTROL

# CMR CONTROLS

A Division of C. M. RICHTER (EUROPE) LTD

22 Repton Court, Repton Close,  
Basildon, Essex SS13 1LN. GB  
Website: <http://www.cmr.co.uk>

Tel: +44 (0)1268 287222  
Fax: +44 (0)1268 287099  
E-mail: [sales@cmr.co.uk](mailto:sales@cmr.co.uk)



### DPC CONTROLLER

Fast and accurate controls to drive high speed dampers or invertors. Full PID stand alone controls with BMS interface.

### CAV AND VAV DAMPERS

Accurate air flow measurement with the unique CMR Venturi built into the airtight shut-off damper to control room pressure or constant volume.

Metal Damper



### PPS EXTRACT DAMPER

Poly-propelene control and shut off valve incorporating the CMR Venturi Nozzle. This is essential when dealing with corrosive extract air especially from fume cupboard systems.

PPS Damper

